

Xpert® Xpress MVP

For use with GeneXpert® System with Touchscreen



Catalog Numbers

REF XPRSMVP-10

REF XPRSMVP-120

303-0949 | Rev. A | 2024-01

Rx only **IVD** In Vitro Diagnostic Medical Device

Trademark, Patents and Copyright Statements

Cepheid®, the Cepheid logo, GeneXpert®, and Xpert® are trademarks of Cepheid, registered in the U.S. and other countries.





All other trademarks are the property of their respective owners.

THE PURCHASE OF THIS PRODUCT CONVEYS TO THE BUYER THE NON-TRANSFERABLE RIGHT TO USE IT IN ACCORDANCE WITH THESE INSTRUCTIONS FOR USE. NO OTHER RIGHTS ARE CONVEYED EXPRESSLY, BY IMPLICATION OR BY ESTOPPEL. FURTHERMORE, NO RIGHTS FOR RESALE ARE CONFERRED WITH THE PURCHASE OF THIS PRODUCT.

© 2024 Cepheid.

See [Revision History](#) for a description of changes.

Table of Contents

	Getting Started.....	5
	Product Information.....	5
	Proprietary Name.....	5
	Common or Usual Name	5
	Intended Use, Summary, and Principle of Procedure	5
	Intended Use.....	5
	Summary and Explanation.....	6
	Principle of the Procedure.....	6
	Reagents, Instruments, and Materials.....	7
	Reagents	7
	Materials Provided.....	7
	Materials Required but not Provided.....	8
	Warnings and Precautions	8
	General.....	8
	Specimen	8
	Test/Reagent.....	9
	Chemical Hazards, Storage and Handling	10
	Chemical Hazards.....	10
	Storage and Handling.....	10
	Specimen Collection, Testing, and Results	11
	Specimen Collection.....	11
	Specimen Collection, Transport, and Storage.....	11
	Procedure	11
	Preparing the Cartridge.....	11
	Starting the Test: GeneXpert System with Touchscreen.....	13
	Viewing Results: GeneXpert System with Touchscreen	14
	Quality Control	14
	External Controls	14
	Results.....	15
	Reasons to Repeat the Test	16
	Retest Procedure	17
	Limitations	17
	Limitations	17
	Expected Values	18
	Specific Performance Characteristics	20
	Clinical Performance	20
	BV Performance Results.....	21

Candida group Performance Results	23
Candida glab-krus Performance Results	26
TV Performance Results.....	29
Multi-Target Detection	31
Non-Determinate Rate.....	33
Analytical Performance.....	34
Analytical Sensitivity (Limit of Detection)	34
Analytical Reactivity (Inclusivity)	35
Analytical Specificity (Cross-reactivity).....	40
Microbial Interference	42
Competitive Interference.....	43
Potentially Interfering Substances.....	46
Carry-over Contamination.....	47
Reproducibility	47
Precision of the BV Target.....	49
Appendix.....	52
Bibliography.....	52
Cepheid Headquarters Locations	52
Technical Assistance.....	53
Table of Symbols	53
Revision History.....	54



Getting Started

Product Information

Proprietary Name

Xpert® Xpress MVP

Common or Usual Name

Xpert Xpress MVP

Intended Use, Summary, and Principle of Procedure

Intended Use

The Xpert® Xpress MVP test, performed on the GeneXpert® Instrument Systems, is an automated qualitative *in vitro* diagnostic test for the detection of DNA targets from anaerobic bacteria associated with bacterial vaginosis (BV), *Candida* species associated with vulvovaginal candidiasis, and *Trichomonas vaginalis*. The Xpert Xpress MVP test uses clinician-collected and self-collected vaginal swabs (collected in a clinical setting) from patients who are symptomatic for vaginitis/vaginosis. The Xpert Xpress MVP test utilizes real-time polymerase chain reaction (PCR) for the amplification of specific DNA targets and utilizes fluorogenic target-specific hybridization probes to detect and differentiate DNA from:

- Organisms associated with bacterial vaginosis (detected organisms not reported individually)
 - *Atopobium* spp. (*Atopobium vaginae*, *Atopobium* novel species CCUG 55226)
 - Bacterial Vaginosis-Associated Bacterium 2 (BVAB2)
 - *Megasphaera*-1
- *Candida* spp. (*C. albicans*, *C. tropicalis*, *C. parapsilosis*, *C. dubliniensis*, species not differentiated)
- *Candida glabrata*/*Candida krusei* (species not differentiated)
- *Trichomonas vaginalis*

The Xpert Xpress MVP test is intended to aid in the diagnosis of vaginal infections in women with a clinical



presentation consistent with bacterial vaginosis, vulvovaginal candidiasis, or trichomoniasis.

Summary and Explanation

The most common causes of vaginosis and vaginitis are: 1) proliferation of one or more anaerobic bacterial species in the vaginal tract leading to vaginal discharge without inflammation (22–50% of symptomatic women), known as bacterial vaginosis; 2) vulvovaginal candidiasis (17–39%); and 3) trichomoniasis (4–35%).¹ Symptoms in undiagnosed women may be caused by a broad array of non-infectious conditions, including atrophic vaginitis, aerobic vaginitis, various vulvar dermatologic conditions, and vulvodynia. Abnormal vaginal discharge has a broad differential diagnosis, and successful treatment typically requires an accurate diagnosis.

Principle of the Procedure

The Xpert Xpress MVP test is an automated *in vitro* diagnostic test for qualitative detection of DNA targets from anaerobic bacteria associated with bacterial vaginosis, *Candida* species associated with vulvovaginal candidiasis, and *Trichomonas vaginalis*, the agent of trichomoniasis. The Xpert Xpress MVP test is performed on GeneXpert Instrument Systems.

The GeneXpert Instrument Systems automate and integrate sample preparation, nucleic acid extraction and amplification, and detection of the target sequences in simple or complex samples using real-time PCR tests. The systems consist of an instrument, computer, and preloaded software for running tests and viewing the results. The systems require the use of single-use disposable cartridges that hold the PCR reagents and host the PCR process. Because the cartridges are self-contained, cross-contamination between samples is minimized. For a full description of the system, see the relevant system operator manual.

The Xpert Xpress MVP test includes reagents for the detection of DNA from BV organisms, *Candida* species, and *Trichomonas vaginalis* from vaginal swab samples. A Sample Processing Control (SPC) and a Probe Check Control (PCC) are also included in the cartridge utilized by the GeneXpert System instrument. The SPC is present to control for adequate processing of the sample and to monitor for the presence of potential inhibitor(s) in the PCR. The SPC also ensures that the PCR conditions (temperature and time) are appropriate for the amplification reaction and that the PCR reagents are functional. The PCC verifies reagent rehydration, PCR tube filling, and confirms that all reaction components are present in the cartridge including monitoring for probe integrity and dye stability.

The Xpert Xpress MVP test is designed for use with the following specimens collected from symptomatic individuals: self-collected vaginal swabs (collected in a clinical setting) and clinician-collected vaginal swabs. The swab transport reagent included in the Xpert Swab Specimen Collection Kit is designed to collect and preserve patient specimens to allow transport to the laboratory prior to analysis with the Xpert Xpress MVP test.

The specimen is briefly mixed by vigorously shaking the collection tube 3 to 4 times. Using the supplied transfer pipette, the sample is transferred to the sample chamber of the Xpert Xpress MVP cartridge. The GeneXpert cartridge is loaded onto the GeneXpert Instrument System platform, which performs hands-off, automated sample processing, and real-time PCR for the detection of DNA. Summary and detailed test results are obtained within 60 minutes and are displayed in tabular and graphic formats.



Reagents, Instruments, and Materials

Reagents

Materials Provided

The Xpert Xpress MVP 10-test kit (XPRSMVP-10) contains sufficient reagents to process 10 specimens or quality control samples and the Xpert Xpress MVP 120-test kit (XPRSMVP-120) contains sufficient reagents to process 120 specimens or quality control samples. Each kit contains the following:

Xpert Xpress MVP cartridges with integrated reaction tubes	10 per kit	120 per kit
• Bead 1, Bead 2, Bead 3 and Bead 4	1 of each per cartridge	1 of each per cartridge
• Lysis Reagent (Guanidinium thiocyanate)	1.3 mL per cartridge	1.3 mL per cartridge
• Sodium Hydroxide	0.44 mL per cartridge	0.44 mL per cartridge
• Binding Reagent	1.5 mL per cartridge	1.5 mL per cartridge
• Wash Reagent	0.48 mL per cartridge	0.48 mL per cartridge
• Elution Reagent	2.0 mL per cartridge	2.0 mL per cartridge
Transfer Pipettes	12 per kit	144 per kit
Instructions for Use CLIA Complexity: Waived (For use with GeneXpert Xpress System only)	1 per kit	1 per kit
Quick Reference Instructions CLIA Complexity: Waived (For use with GeneXpert Xpress System only)	1 per kit	1 per kit



CD

1 per kit

1 per kit

- Assay Definition File (ADF)
- Instructions to import ADF into GeneXpert software
- Instructions for Use

Note Safety Data Sheets (SDS) are available at www.cephheid.com or www.cephheidinternational.com under the **SUPPORT** tab.

Note The bovine serum albumin (BSA) in the beads within this product was produced and manufactured exclusively from bovine plasma sourced in the United States. No ruminant protein or other animal protein was fed to the animals; the animals passed ante- and post-mortem testing. During processing, there was no mixing of the material with other animal materials.

Materials Required but not Provided

- GeneXpert system with touchscreen: GeneXpert instrument, touchscreen unit with built-in scanner, Cepheid OS software version 2.0 or higher, and operator manual.
- Samples must be collected and transported with the Xpert Swab Specimen Collection kit (catalog number SWAB/G-50-US).

Warnings and Precautions

General

- For *in vitro* diagnostic use. 
- Treat all biological samples, including used cartridges, as if capable of transmitting infectious agents. Because it is often impossible to know which might be infectious, all biological samples should be handled using standard precautions. Guidelines for sample handling are available from the U.S. Centers for Disease Control and Prevention² and the Clinical and Laboratory Standards Institute.³
- Follow safety procedures set by your institution for working with chemicals and handling biological samples.
- Consult your institution's environmental waste personnel on proper disposal of used cartridges, which may contain amplified material. This material may exhibit characteristics of Federal EPA Resource Conservation and Recovery Act (RCRA) hazardous waste requiring specific disposal requirements. Check state and local regulations as they may differ from federal disposal regulations. Institutions should check the hazardous waste disposal requirements within their respective countries.
- Do not open or alter any part of the used cartridge for disposal.

Specimen

- For collection and transport of vaginal swab samples, use only the Xpert Swab Specimen Collection Kit.
- Vaginal swab samples must be collected and tested before the expiration date printed on the Xpert Swab Specimen Collection Kit.
- Maintain proper storage conditions during sample transport to ensure the integrity of the sample (see [Specimen Collection, Transport, and Storage](#)). Samples placed in transport medium following collection can be stored for up to 42 days at 2–28°C. Sample stability under shipping/storage conditions other than those recommended has not been evaluated.



Test/Reagent

- Do not use a cartridge that has been dropped after removing from the kit or that has been shaken after the cartridge lid has been opened. Shaking or dropping the cartridge after opening the lid may yield non-determinate results.

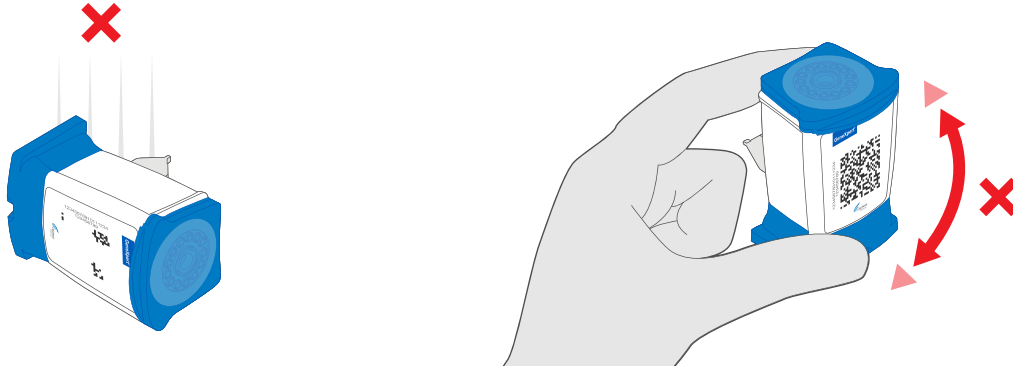

- Do not place the sample ID label on the cartridge lid or on the barcode label.



- Hold the cartridge by the base. Do not touch the reaction tube at the rear of the cartridge as this could cause damage that would interfere with light passing through it during the test. Do not use a cartridge with a damaged or missing reaction tube.

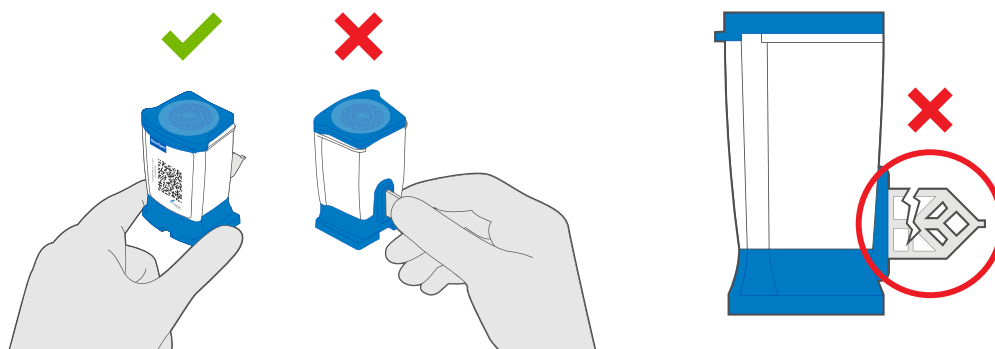

- Do not open the Xpert Xpress MVP cartridge lid except when adding specimen.
- Do not use a cartridge with a damaged barcode label.
- Each single-use Xpert Xpress MVP cartridge is used to process one test. Do not reuse processed cartridges.
- Each single-use disposable pipette is used to transfer one specimen. Do not reuse disposable pipettes.
- Do not use a cartridge if it appears wet or if the lid seal appears to have been broken.
- Wear clean lab coats and gloves. Change gloves between the handling of each specimen.



- In the event of a spill of specimens or controls, wear gloves and absorb the spill with paper towels. Then, thoroughly clean the contaminated area with a 1:10 dilution of freshly prepared household chlorine bleach. Final active chlorine concentration should be 0.5% regardless of the household bleach concentration in your country. Allow a minimum of two minutes of contact time. Ensure the work area is dry before using 70% denatured ethanol to remove bleach residue. Allow surface to dry completely before proceeding. Or, follow your institution's standard procedures for a contamination or spill event. For equipment, follow the manufacturer's recommendations for decontamination of equipment.
- Biological specimens, transfer devices, and used cartridges should be considered capable of transmitting infectious agents requiring standard precautions. Follow your institution's environmental waste procedures for proper disposal of used cartridges and unused reagents. These materials may exhibit characteristics of chemical hazardous waste requiring specific disposal. If country or regional regulations do not provide clear direction on proper disposal, biological specimens and used cartridges should be disposed per WHO [World Health Organization] medical waste handling and disposal guidelines.

Chemical Hazards, Storage and Handling

Chemical Hazards⁴

- **UN GHS Signal Word: Warning**
- **UN GHS Hazard Statements:**
 - May be harmful if swallowed.
 - May be harmful in contact with skin.
 - Causes eye irritation.
- **UN GHS Hazard Statements:**
 - **Prevention**
 - Wash thoroughly after handling.
 - **Response**
 - Call a POISON CENTER or doctor/physician if you feel unwell.
 - If skin irritation occurs: Get medical advice/attention.
 - IF IN EYES: Rinse cautiously with water for several minutes. Remove contact lenses, if present and easy to do. Continue rinsing.
 - If eye irritation persists: Get medical advice/attention.

Storage and Handling

- Store the Xpert Xpress MVP cartridges at 2–28°C until the expiration date provided on the label.
- Do not use expired cartridges.
- Do not open a cartridge lid until you are ready to perform testing.
- Do not use a cartridge that is wet or has leaked.
- Do not open or alter any part of the used cartridge for disposal.

Specimen Collection, Testing, and Results

Specimen Collection

Specimen Collection, Transport, and Storage

- Proper sample collection, storage, and transport are critical to the performance of this test. Inadequate sample collection, improper sample handling and/or transport may yield a false result. Samples should be transported at 2–28°C.
- Samples placed in transport medium following collection can be stored for up to 42 days at 2–28°C prior to testing with the Xpert Xpress MVP test.
- Refer to the Xpert Swab Specimen Collection Kit Instructions for Use for collection and transport instructions.

Procedure

Preparing the Cartridge

 **Important** Start the test within 30 minutes of adding the sample to the cartridge.

1. Obtain a new Xpert Xpress MVP cartridge and a new transfer pipette provided in the Xpert Xpress MVP test kit.
2. Open the cartridge by lifting the front of the cartridge lid.
3. Check that the specimen transport tube cap is closed, then vigorously shake the specimen transport tube 3 to 4 times.
Note Not shaking or inadequate shaking of the specimen transport tube may generate false negative results.
4. Open the lid on the specimen transport tube.
5. Remove the transfer pipette from the wrapper.
6. Squeeze the top bulb of the transfer pipette **completely until the top bulb is fully flat**. While continuing to hold the bulb fully flat, place the pipette tip in the specimen transport tube (see [Figure 1](#)).

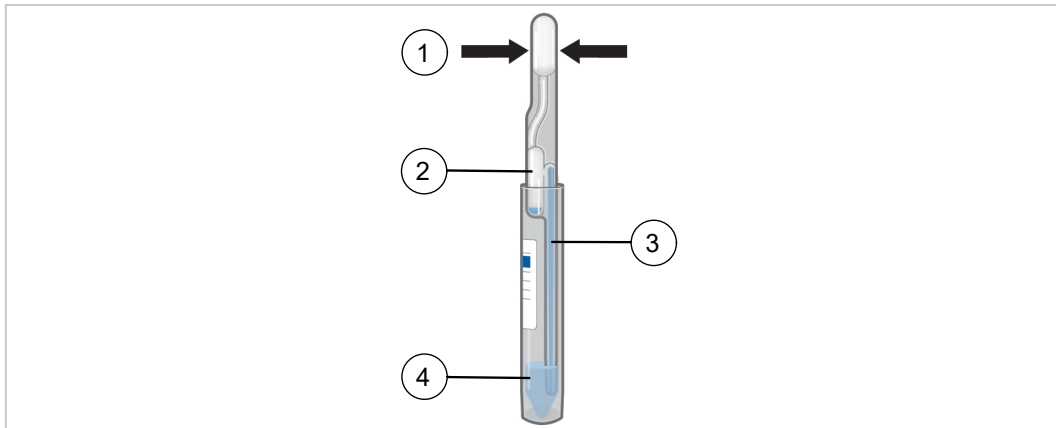

Figure 1 Transfer Pipette

Number	Description
1	Top Bulb (Squeeze here until fully flat)
2	Overflow Reservoir Bulb (Do Not Squeeze)
3	Pipette
4	Sample

7. Keeping the pipette below the surface of the liquid, release the top bulb of the pipette **slowly until the pipette is completely filled with sample** before removing it from the tube. After filling the pipette, excess sample may be seen in the overflow reservoir bulb of the pipette (see Figure 1). It is okay if liquid goes into the overflow reservoir. Check that the pipette does not contain bubbles.
8. To transfer the sample to the cartridge, put the pipette into the large opening on the lower right corner of the cartridge (see green arrow on sample chamber) shown in Figure 2. Squeeze the top bulb of the transfer pipette **completely until it is fully flat** to empty the contents.



Figure 2 Xpert Xpress MVP Cartridge

9. Continue to **hold the top bulb fully flat and do not release** until the pipette is removed from the cartridge. **Do not reuse a pipette.** Dispose of the used pipette in an appropriate waste container after use.
Note Take care to dispense the entire volume of liquid from the transfer pipette into the sample chamber. Non-determinate results may occur if insufficient sample is added to the cartridge.
10. Close the cartridge lid.



Note Time to result is within 60 minutes.

Starting the Test: GeneXpert System with Touchscreen

i Important Before you start the test, make sure that:

- The system is running the correct Cepheid OS software version shown in section - **Materials Required but Not Provided.**
- The correct assay definition file is imported into the software.

Note The default workflow is shown. Your system administrator may alter the workflow.

1. Turn on GeneXpert system with touchscreen.
2. Log on to system software using your username and password.
3. On the Modules tab, touch **Start Test.**
4. Follow onscreen prompts to create new test and enter patient and sample information.
5. Scan or manually input the cartridge serial number. If scanning, hold the cartridge about 1-3 inches (3-7 cm) away from the scanner. The scanner projects a green crosshair, which you center on the barcode. Scanning is complete when you hear an audible beep. Touch **Continue.**

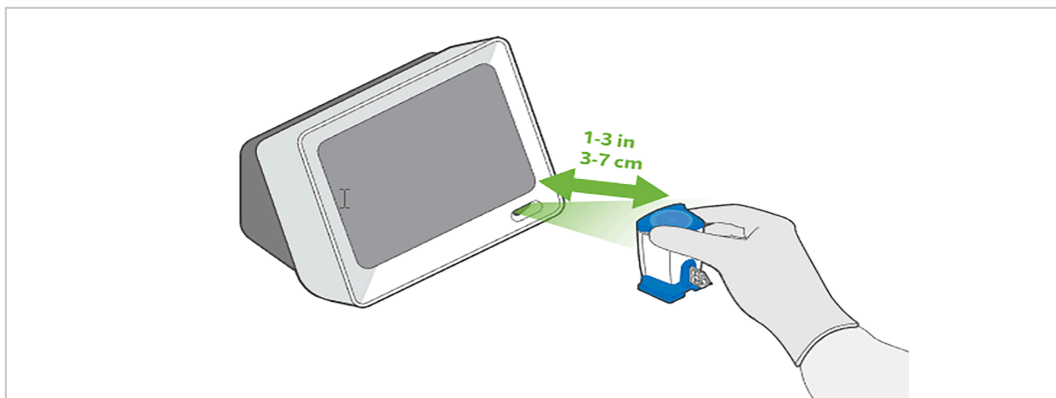

6. Select the desired test and touch **Continue.**
7. Watch the cartridge preparation video, if needed.
8. On the Confirm screen, review all data and touch **Confirm.**
9. Open the module door under flashing green light and insert the cartridge.

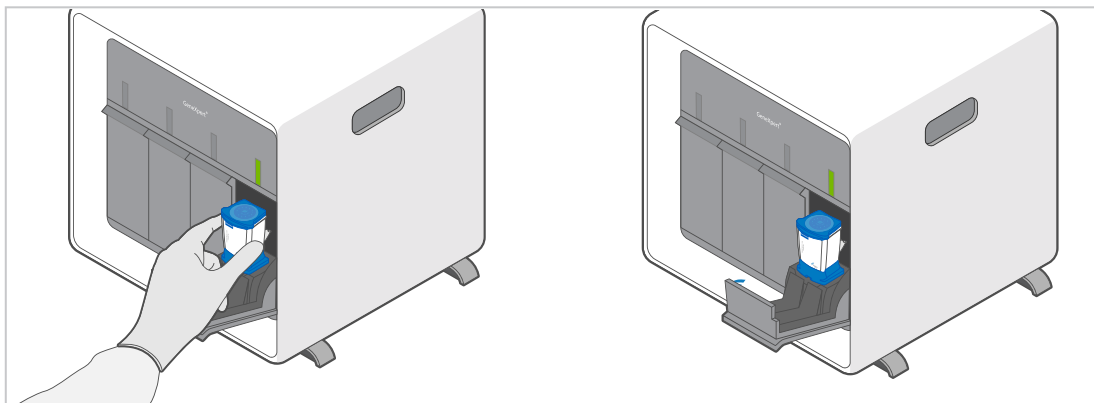



10. Close cartridge module door completely by pressing until it latches. The test starts.

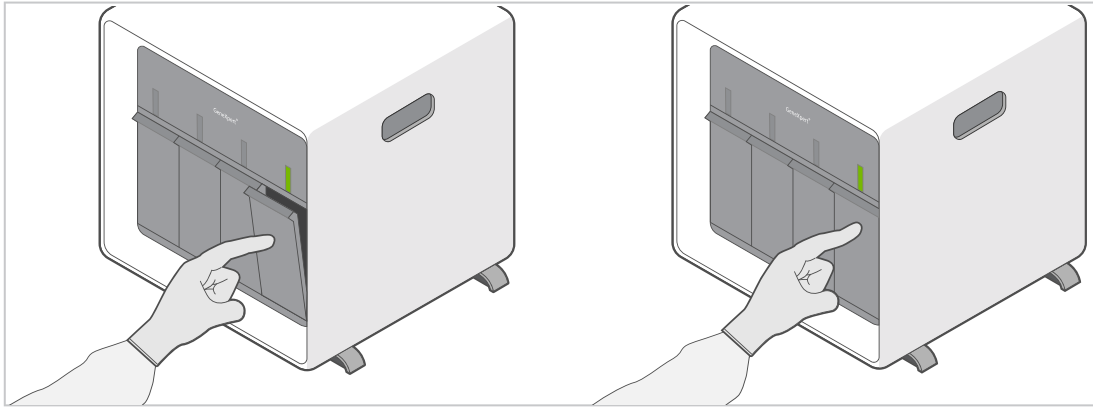

11. When the test completes, the **Results Summary** screen appears. Open the module door and remove cartridge.
12. Dispose of used cartridge in appropriate waste container according to your institution's standard practices.

Viewing Results: GeneXpert System with Touchscreen

The GeneXpert System with Touchscreen results screen will automatically interpret test results for you and clearly show them in the **View Results** window.

1. Tap **Results**.
2. Tap the test to be viewed in the Results screen.
3. Click **OK**.
4. To generate a PDF report file, touch **View Report**. More detailed instructions for viewing and uploading results are available in your system operator manual.

Quality Control

Each test includes a Sample Processing Control (SPC) and Probe Check Control (PCC).

Sample Processing Control (SPC) – Ensures that the sample is processed correctly. The SPC verifies that sample processing is adequate. Additionally, this control detects sample-associated inhibition of the real-time PCR test, ensures that the PCR conditions (temperature and time) are appropriate for the amplification reaction, and that the PCR reagents are functional. The SPC should be positive in a negative sample and can be negative or positive in a positive sample. The SPC passes if it meets the validated acceptance criteria.

Probe Check Control (PCC) – Before the start of the PCR, the GeneXpert System measures the fluorescence signal from the probes to monitor bead rehydration, reaction tube filling, probe integrity, and dye stability. The PCC passes if it meets the validated acceptance criteria.

External Controls

Use external control materials in accordance with local, state, federal regulations, and accreditation requirements.

To run a control using the Xpert Xpress MVP test:



1. Have a new Xpert Xpress MVP test cartridge, a transfer pipette provided in the Xpert Xpress MVP test kit, and a quality control tube ready.
2. Open the cartridge lid.
3. Vigorously shake the external control sample 3 to 4 times.
4. Using a clean transfer pipette, squeeze the top bulb of the transfer pipette **completely until the top bulb is fully flat**. While continuing to hold the bulb fully flat, place the pipette tip in the external control tube (see [Figure 1](#)). Keeping the pipette below the surface of the liquid, release the top bulb of the pipette **slowly until the pipette is completely filled with sample** before removing it from the tube. Check that the pipette does not contain bubbles.
5. Squeeze the top bulb of the transfer pipette completely again to empty the contents of the pipette into the large opening (see green arrow on sample chamber) in the cartridge shown in [Figure 2](#). Continue to **hold the top bulb fully flat and do not release** until the pipette is removed from the cartridge. Dispose of the used pipette.
6. Close the cartridge lid.

Results

The results are interpreted automatically by the GeneXpert System and are clearly shown in the **View Results** window. Some of the possible results and interpretations are shown in [Table 1](#); additional combinations of results are possible and likely to occur.

Table 1. Xpert Xpress MVP Results and Interpretations

Result	Interpretation
BV NEGATIVE Candida group NOT DETECTED Candida glab- krus NOT DETECTED TV NOT DETECTED	Indicator DNA target(s) related to bacterial vaginosis (BV) organisms is/are not detected (see Table 2); Candida group (<i>C. albicans</i> and/or <i>C. tropicalis</i> and/or <i>C. parapsilosis</i> and/or <i>C. dubliniensis</i>) target DNA is not detected; Candida glab-krus (<i>Candida glabrata</i> and/or <i>C. krusei</i>) target DNA is not detected; and <i>Trichomonas vaginalis</i> (TV) target DNA is not detected. <ul style="list-style-type: none"> • SPC: PASS; SPC has a Ct within the valid range and endpoint above the threshold setting. • PCC: PASS; all probe check results pass.
BV POSITIVE Candida group DETECTED Candida glab- krus DETECTED TV DETECTED	Indicator DNA target(s) related to bacterial vaginosis (BV) organisms is/are detected (see Table 2); Candida group (<i>C. albicans</i> and/or <i>C. tropicalis</i> and/or <i>C. parapsilosis</i> and/or <i>C. dubliniensis</i>) target DNA is detected; Candida glab-krus (<i>Candida glabrata</i> and/or <i>C. krusei</i>) target DNA is detected; and <i>Trichomonas vaginalis</i> (TV) target DNA is detected. <ul style="list-style-type: none"> • BV, Candida group, Candida glab-krus, and TV: Ct values are within the valid range. • SPC: NA (not applicable); SPC signal is not part of the result interpretation algorithm if the target DNA is detected since SPC signal may be suppressed due to competition with BV, Candida group, Candida glab-krus, and TV targets. • PCC: PASS; all probe check results pass.



Result	Interpretation
INVALID	<p>Presence or absence of the target DNA cannot be determined.</p> <ul style="list-style-type: none"> BV, Candida group, Candida glab-krus, and TV: one or more of the analyte results is INVALID. SPC: FAIL or NA. PCC: PASS; all probe check results pass. <p>Note If SPC shows NA, the INVALID may be caused by a test parameter failure.</p> <p>Repeat test according to the instructions in Retest Procedure.</p>
ERROR	<p>Presence or absence of BV, Candida group, Candida glab-krus, and TV target DNA cannot be determined</p> <ul style="list-style-type: none"> BV, Candida group, Candida glab-krus, and TV: NO RESULT SPC: NO RESULT PCC: FAIL; all or one of the probe check results fail. <p>Note If the probe check passes or shows NA, the error may be caused by the maximum pressure limit exceeding the acceptable range, insufficient sample volume or by a system component failure.</p> <p>Repeat test according to the instructions in Retest Procedure.</p>
NO RESULT	<p>Presence or absence of BV, Candida group, Candida glab-krus, and TV target DNA cannot be determined. A NO RESULT indicates that insufficient data were collected. For example, cartridge integrity test failed, the operator stopped a test that was in progress or a power failure occurred.</p> <ul style="list-style-type: none"> BV, Candida group, Candida glab-krus, and TV: NO RESULT SPC: NO RESULT PCC: NA (not applicable)* <p>Note If the probe check shows NA, the error may be caused by the maximum pressure limit exceeding the acceptable range and terminates the run prior to probe check.</p> <p>Repeat test according to the instructions in Retest Procedure.</p>

Table 2 presents the BV algorithm and the expected results.

Table 2. BV Results Algorithm^A

BV Organisms			BV Result
<i>Atopobium</i> spp. ^b	<i>Megasphaera</i> -1	BVAB2	
+	+	-	BV Positive
+	-	+	BV Positive
+	+	+	BV Positive
+ (high concentration)	-	-	BV Positive
-	+/-	+/-	BV Negative

a. Algorithm results are either BV positive or BV negative.

b. *Atopobium vaginae* and/or *Atopobium* novel species CCUG 55226.

Reasons to Repeat the Test

If any of the test results mentioned below occur, repeat the test once according to instructions in [Retest Procedure](#).

- An **INVALID** result indicates that the control SPC failed or a test parameter failed. The sample was not properly processed, PCR was inhibited, or the sample was not properly collected.
- An **ERROR** result could be due to, but not limited to, Probe Check Control failure, system component failure, insufficient sample volume, or the maximum pressure limits were exceeded.



- A **NO RESULT** indicates that insufficient data were collected. For example, cartridge failed integrity test, the operator stopped a test that was in progress, or a power failure occurred.

If an External Control fails to perform as expected, repeat external control test and/or contact Cepheid Technical Support for assistance.

Retest Procedure

To retest an **INVALID**, **NO RESULT**, or **ERROR** result (non-determinate result), use a new cartridge.

Use the leftover sample from the original specimen transport tube.

1. Put on a clean pair of gloves. Obtain a new Xpert Xpress MVP cartridge and a transfer pipette provided in the Xpert Xpress MVP test kit.
2. Mix the sample by vigorously shaking the specimen transport tube 3 to 4 times. Open the cap on the specimen transport tube.
3. Open the cartridge lid.
4. Using a clean transfer pipette (supplied), transfer sample (one draw) to the sample chamber with the large opening in the cartridge.
5. Dispose of the used cartridge and gloves in an appropriate sample waste container according to your institution's standard practices.

Limitations

Limitations

- The Xpert Xpress MVP test has been validated using only the procedures provided in this Instructions for Use. Modification to these procedures may alter the performance of the test.
- The Xpert Xpress MVP test has been validated with vaginal swabs collected with the Xpert Swab Specimen Collection Kit.
- Testing of vaginal swab specimens with the Xpert Xpress MVP test is not intended to replace an exam by a clinician. Vaginal infections may result from other causes or concurrent infections may occur.
- As with many diagnostic tests, results from the Xpert Xpress MVP test should be interpreted in conjunction with other laboratory and clinical data available to the clinician.
- Public health recommendations should be consulted regarding testing for additional sexually transmitted diseases for patients with a positive result for bacterial vaginosis (BV) or *T. vaginalis* with the Xpert Xpress MVP test.
- The Xpert Xpress MVP test targets three anaerobic microorganisms that are associated with BV. Other organisms that are not detected by the Xpert Xpress MVP test have also been reported to be associated with BV and aerobic vaginitis.
- A *Candida* group positive result can be due to one or multiple *Candida* species.
- *Candida* species can be present as commensal organisms in women; the Xpert Xpress MVP positive results for *Candida* should be considered in conjunction with other clinical and patient information to determine the disease status.
- The BV organism targets of the Xpert Xpress MVP test can be commensal in women; Xpert Xpress MVP positive results for bacterial vaginosis should be considered in conjunction with other clinical and patient information to determine the disease status.



- Erroneous test results might occur from improper specimen collection, technical error, sample mix-up, or because the number of organisms in the specimen is not detected by the test. Careful compliance with the instructions in this Instructions for Use and the Xpert Swab Specimen Collection Kit instruction documents are necessary to avoid erroneous results.
- A negative test result does not exclude the possibility of infection because test results may be affected by improper specimen collection, technical error, specimen mix-up, concurrent antibiotic therapy, or the number of organisms in the specimen that may be below the sensitivity of the tests.
- False negative results may occur if the organism(s) is present at levels below the analytical limit of detection below the cut-off concentration or outside the BV algorithm parameters for a positive result.
- Mutations or other changes within the regions of the microbial genomes covered by the primers and/or probes in the Xpert Xpress MVP test may result in failure to detect the target organisms.
- The effects of other potential variables such as vaginal discharge, use of tampons, douching, and specimen collection variables have not been determined.
- The Xpert Xpress MVP test provides qualitative results. No correlation can be drawn between the magnitude of the Ct value and the number of cells in an infected sample.
- The Xpert Xpress MVP test performance has been evaluated in patients 14 years of age and older (including pregnant women).
- The Xpert Xpress MVP test has not been validated for use with vaginal swab specimens collected by patients at home. The self-collected vaginal swab specimen application is limited to healthcare facilities where support/counseling is available to explain procedures and precautions.
- Five strains of *Candida albicans* evaluated in the Inclusivity Study were detected by the Xpert Xpress MVP test. Three of the strains were only detected at concentrations higher than 3× LoD (one strain at 4× LoD and two strains at 20× LoD).
- Eleven strains of *Atopobium* spp. evaluated in the Inclusivity Study were detected by the Xpert Xpress MVP test. Four of the strains were only detected at concentrations higher than 3× near cut-off concentration (ranging from 4× and 12×).
- *Candida orthopsilosis*, a recently described species that has been grouped previously with *C. parapsilosis*, was found to cross-react with the Xpert Xpress MVP test at levels above 1×10² CFU/mL. *Pentatrichomonas hominis* (a commensal of the large intestine) was found to cross-react with the Xpert Xpress MVP test at levels above 5×10⁴ cells/mL. *Trichomonas tenax* (a commensal of the oral cavity) was found to cross-react with the Xpert Xpress MVP test at levels above 10 cells/mL. See [Analytical Specificity \(Cross-reactivity\)](#) for details.
- Interference with the Xpert Xpress MVP test was observed in the presence of mucin (from porcine stomach) (≥5.5% v/v). See [Potentially Interfering Substances](#) for details.
- The analyte target may persist *in vivo*, independent of pathogen viability. Detection of the analyte target does not imply that the corresponding pathogen is infectious, or is the causative agent of the clinical symptoms.
- The Xpert Xpress MVP test cannot be used to assess therapeutic success or failure since target nucleic acids may persist following antimicrobial therapy.

Expected Values

Positivity rates in the symptomatic patient population, as observed in the clinical study determined by the Xpert Xpress MVP test, were calculated from clinician-collected vaginal swab (CVS) and self-collected vaginal swab (SVS) specimens and are presented by target and by race/ethnicity in [Table 3](#).



Table 3. Positivity Rates in Symptomatic Patients

	Target	Overall	Black /African American		White		Asian	Others ^a
			Hispanic/Latino	Not Hispanic/ Latino	Hispanic/Latino	Not Hispanic/Latino		
CVS	BV	40.9% (588/1436)	62.5% (10/16)	59.5% (327/550)	37.7% (72/191)	24.9% (154/618)	23.8% (5/21)	50.0% (20/40)
	Candida group	31.2% (453/1450)	43.8% (7/16)	34.4% (191/555)	32.0% (62/194)	27.9% (173/621)	31.8% (7/22)	31.0% (13/42)
	Candida glab-krus	3.4% (49/1450)	0% (0/16)	4.1% (23/555)	3.1% (6/194)	3.1% (19/621)	0% (0/22)	2.4% (1/42)
	TV	5.5% (78/1423)	0% (0/16)	11.4% (62/545)	2.7% (5/188)	1.6% (10/613)	0% (0/21)	2.5% (1/40)
SVS	BV	41.8% (598/1431)	62.5% (10/16)	59.4% (325/547)	37.5% (72/192)	26.7% (165/618)	30.0% (6/20)	52.6% (20/38)
	Candida group	32.9% (476/1445)	37.5% (6/16)	35.7% (197/552)	34.4% (67/195)	30.3% (188/621)	28.6% (6/21)	30.0% (12/40)
	Candida glab-krus	3.7% (54/1445)	0% (0/16)	4.2% (23/552)	3.1% (6/195)	3.9% (24/621)	0% (0/21)	2.5% (1/40)
	TV	5.3% (75/1418)	0% (0/16)	4.2% (23/542)	2.6% (5/189)	1.5% (9/613)	0% (0/20)	2.6% (1/38)

a. Including: American Indian or Alaska Native, Native Hawaiian or Other Pacific Islander, Mixed/Unknown

Although the Xpert Xpress MVP test is not intended for use in an asymptomatic patient population, positivity rates were calculated from CVS and SVS specimens collected from asymptomatic patients to assess how often patients who, despite being asymptomatic, harbored microbial flora associated with vaginosis and candidiasis that could be detected by the Xpert Xpress MVP test. Positivity rates are presented by target and by race/ethnicity in [Table 4](#).

Table 4. Positivity Rates in Asymptomatic Patients

	Target	Overall	Black /African American ^a	White		Others ^b
				Hispanic/Latino	Not Hispanic/Latino	
CVS	BV	32.9% (52/158)	51.0% (26/51)	25.5% (14/55)	19.5% (8/41)	36.4% (4/11)
	Candida group	17.1% (27/158)	25.5% (13/51)	16.4% (9/55)	7.3% (3/41)	18.2% (2/11)
	Candida glab-krus	4.4% (7/158)	2.0% (1/51)	5.5% (3/55)	4.9% (2/41)	9.1% (1/11)
SVS	BV	31.5% (51/162)	49.1% (26/53)	24.1% (13/54)	16.3% (7/43)	41.7% (5/12)
	Candida group	19.1% (31/162)	28.3% (15/53)	18.5% (10/54)	7.0% (3/43)	25.0% (3/12)
	Candida glab-krus	4.9% (8/162)	1.9% (1/53)	7.4% (4/54)	4.7% (2/43)	8.3% (1/12)

a. Includes one Black/African American who was of Hispanic or Latino descent for CVS specimens; includes two Black/African Americans who were of Hispanic or Latino descent for SVS specimens.

b. Including: American Indian or Alaska Native, Asian, Mixed/Unknown

! Specific Performance Characteristics

Clinical Performance

A blinded clinical study was conducted to evaluate the performance of the Xpert Xpress MVP test at 12 geographically diverse sites in the U.S. Subjects included female patients ≥ 14 years of age who presented with signs and/or symptoms of vaginosis/vaginitis. For eligible subjects, one (1) self-collected (collected in a clinical setting, SVS) and five (5) clinician-collected vaginal swab (CVS) specimens were obtained for testing with the Xpert Xpress MVP test and reference/comparator testing. Patient management continued at the site per the standard practice, independent of investigational test results.

The Xpert Xpress MVP test performance was compared to the following reference/comparator methods: an FDA-cleared nucleic acid amplification test (NAAT) for the BV target, yeast culture followed by mass spectrometry identification for the Candida group and Candida glab-krus targets, a patient infected status (PIS) algorithm that included a combination of NAAT and culture results for the TV target. When applicable, investigation of discrepant results was performed by testing specimens with another FDA-cleared NAAT.

The study population comprised of 1,476 female patients 18 to ≥ 50 years of age. Additionally, two patients between 14–17 years of age were enrolled in the study. A total of 2,947 vaginal swabs (1473 CVS and 1474 SVS specimens) were tested and were eligible for inclusion in the Xpert Xpress MVP study.

Performance of the Xpert Xpress MVP test is presented in [Table 5](#). The Xpert Xpress MVP test demonstrated positive percent agreement (PPA) and negative percent agreement (NPA) of 93.8% and 93.8% for BV detection in CVS specimens, respectively, and 94.0% and 92.9% in SVS specimens, respectively. For Candida group detection, the Xpert Xpress MVP test demonstrated sensitivity and specificity of 98.0% and 94.6% in CVS specimens, respectively, and 97.5% and 92.1% in SVS specimens, respectively. The Xpert Xpress MVP test demonstrated sensitivity and specificity of 93.6% and 99.6% for Candida glab-krus detection in CVS specimens, respectively, and 97.8% and 99.4% in SVS specimens, respectively. For TV detection, the Xpert Xpress MVP test demonstrated PPA and NPA of 97.3% and 99.6% in CVS specimens, respectively, and 97.3% and 99.8% in SVS specimens, respectively.

**Table 5. Performance of the Xpert Xpress MVP Test**

	Clinician-collected (CVS)		Self-collected (SVS)	
	Sensitivity/PPA (95% CI)	Specificity/NPA (95% CI)	Sensitivity/PPA (95% CI)	Specificity/NPA (95% CI)
BV	93.8% 531/566 ^a (91.5% - 95.5%)	93.8% 808/861 ^b (92.0% - 95.3%)	94.0% 533/567 ^c (91.7% - 95.7%)	92.9% 794/855 ^d (90.9% - 94.4%)
Candida group ^e	98.0% 396/404 ^f (96.1% - 99.0%)	94.6% 984/1040 ^g (93.1% - 95.8%)	97.5% 393/403 ^h (95.5% - 98.7%)	92.1% 954/1036 ⁱ (90.3% - 93.6%)
Candida glab-krus Fresh Prospective	93.6% 44/47 ^j (82.8% - 97.8%)	99.6% 1392/1397 ^k (99.2% - 99.9%)	97.8% 45/46 ^l (88.7% - 99.6%)	99.4% 1384/1393 ^m (98.8% - 99.7%)
Candida glab-krus Contrived ⁿ	99.0% 98/99 (94.5% - 99.8%)	96.4% 27/28 (82.3% - 99.4%)	N/A	N/A
TV	97.3% 73/75 ^o (90.8% - 99.3%)	99.6% 1332/1337 ^p (99.1% - 99.8%)	97.3% 72/74 ^q (90.7% - 99.3%)	99.8% 1330/1333 ^r (99.3% - 99.9%)

- a. Testing results with a second FDA-cleared NAAT: 14 were also negative and 21 were positive.
- b. Testing results with a second FDA-cleared NAAT: 25 were also positive and 28 were negative.
- c. Testing results with a second FDA-cleared NAAT: 12 were also negative and 22 were positive.
- d. Testing results with a second FDA-cleared NAAT: 23 were also positive and 38 were negative.
- e. Target includes *C. albicans*, *C. tropicalis*, *C. parapsilosis*, and *C. dubliniensis*
- f. Testing results with an FDA-cleared NAAT: 5 were also negative and 3 were positive.
- g. Testing results with an FDA-cleared NAAT: 31 were also positive, 24 were negative and 1 had no result.
- h. Testing results with an FDA-cleared NAAT: 5 were also negative and 5 were positive.
- i. Testing results with an FDA-cleared NAAT: 38 were also positive, 43 were negative and 1 had no result.
- j. Testing results with an FDA-cleared NAAT: 2 were also negative and 1 was positive.
- k. Testing results with an FDA-cleared NAAT: 5 were negative.
- l. Testing results with an FDA-cleared NAAT: 1 was also negative.
- m. Testing results with an FDA-cleared NAAT: 9 were negative.
- n. Contrived specimens were prepared using individual negative clinical CVS and SVS specimens. See [Table 14](#) below for stratified results for *Candida glabrata* and *Candida krusei*
- o. Testing results a second FDA-cleared NAAT: 1 was also negative and 1 was positive.
- p. Testing results a second FDA-cleared NAAT: 4 were also positive and 1 had no result.
- q. Testing results a second FDA-cleared NAAT: 1 was also negative and 1 was positive.
- r. Testing results a second FDA-cleared NAAT: 3 were also positive.

BV Performance Results

[Table 6](#) presents BV performance stratified by age groups in clinician-collected and self-collected swab specimens. The PPA was greater than 93.0% in all age groups except for patients aged 50 and over, in whom the PPA was 87.5% and 87.3% in CVS and SVS specimen collection types, respectively. The NPA of > 90% was observed across all age groups and specimen collection types.

**Table 6. BV Performance by Age Group**

Age Group	Clinician-collected (CVS)		Self-collected (SVS)	
	PPA (95% CI)	NPA (95% CI)	PPA (95% CI)	NPA (95% CI)
14–17	100% 1/1 (20.6% - 100%)	100% 1/1 (20.6% - 100%)	100% 1/1 (20.6% - 100%)	100% 1/1 (20.6% - 100%)
18–29	93.4% 228/244 (89.6% - 95.9%)	92.1% 279/303 (88.5% - 94.6%)	93.1% 228/245 (89.2% - 95.6%)	90.7% 273/301 (86.9% - 93.5%)
30–39	95.3% 164/172 (91.1% - 97.6%)	96.3% 206/214 (92.8% - 98.1%)	96.0% 167/174 (91.9% - 98.0%)	93.9% 201/214 (89.9% - 96.4%)
40–49	95.7% 89/93 (89.5% - 98.3%)	91.9% 125/136 (86.1% - 95.4%)	96.7% 89/92 (90.8% - 98.9%)	90.4% 122/135 (84.2% - 94.3%)
≥ 50	87.5% 49/56 (76.4% - 93.8%)	95.2% 197/207 (91.3% - 97.4%)	87.3% 48/55 (76.0% - 93.7%)	96.6% 197/204 (93.1% - 98.3%)

Performance of the BV target stratified by race and ethnicity subgroups showed PPA and NPA ranging from 80.0% to 100% in most subgroups in CVS and SVS specimens (Table 7).

Table 7. BV Performance by Race and Ethnicity

Race/Ethnicity	Clinician-collected (CVS)		Self-collected (SVS)	
	PPA (95% CI)	NPA (95% CI)	PPA (95% CI)	NPA (95% CI)
White	88.9% 193/217 (84.1% - 92.4%)	94.9% 554/584 (92.8% - 96.4%)	90.0% 198/220 (85.3% - 93.3%)	93.8% 546/582 (91.6% - 95.5%)
Black or African American	97.2% 316/325 (94.8% - 98.5%)	91.7% 220/240 (87.5% - 94.5%)	96.9% 313/323 (94.4% - 98.3%)	91.2% 218/239 (86.9% - 94.2%)
Asian	80.0% 4/5 (37.5% - 96.4%)	93.8% 15/16 (71.7% - 98.9%)	80.0% 4/5 (37.5% - 96.4%)	86.7% 13/15 (62.1% - 96.3%)
American Indian or Alaska Native	83.3% 5/6 (43.6% - 97.0%)	80.0% 4/5 (37.5% - 96.4%)	83.3% 5/6 (43.6% - 97.0%)	80.0% 4/5 (37.5% - 96.4%)
Native Hawaiian or Other Pacific Islander	100% 2/2 (34.2% - 100%)	0% 0/1 (0% - 79.3%)	100% 2/2 (34.2% - 100%)	0% 0/1 (0% - 79.3%)
Mixed/Unknown	100% 11/11 (74.1% - 100%)	100% 15/15 (79.6% - 100%)	100% 11/11 (74.1% - 100%)	100% 13/13 (77.2% - 100%)
Hispanic or Latino	93.9% 77/82 (86.5% - 97.4%)	93.2% 123/132 (87.6% - 96.4%)	95.2% 79/83 (88.2% - 98.1%)	94.7% 124/131 (89.4% - 97.4%)



Performance of BV target in subgroups based on clinical conditions at the time of specimen collection is presented in [Table 8](#). Results showed PPA of $\geq 87.5\%$ except in subgroup of patients using estrogen therapy and NPA of $\geq 85.2\%$ in all subgroups across in CVS and SVS specimen collection types.

Table 8. BV Performance by Clinical Condition

Clinical Condition	Clinician-collected (CVS)		Self-collected (SVS)	
	PPA (95% CI)	NPA (95% CI)	PPA (95% CI)	NPA (95% CI)
Pregnant patients	93.3% 42/45 (82.1% - 97.7%)	89.5% 51/57 (78.9% - 95.1%)	95.6% 43/45 (85.2% - 98.8%)	91.1% 51/56 (80.7% - 96.1%)
Patients with menses at enrollment	97.2% 35/36 (85.8% - 99.5%)	92.6% 50/54 (82.4% - 97.1%)	94.1% 32/34 (80.9% - 98.4%)	85.2% 46/54 (73.4% - 92.3%)
Patients using anti-fungals ≤ 24 hours	93.3% 14/15 (70.2% - 98.8%)	100% 36/36 (90.4% - 100%)	87.5% 14/16 (64.0% - 96.5%)	100% 34/34 (89.8% - 100%)
Patients using antibiotics ≤ 24 hours	100% 8/8 (67.6% - 100%)	93.3% 14/15 (70.2% - 98.8%)	100% 8/8 (67.6% - 100%)	93.3% 14/15 (70.2% - 98.8%)
Patients using estrogen therapy ≤ 24 hours	66.7% 2/3 (20.8% - 93.8%)	100% 18/18 (82.4% - 100%)	66.7% 2/3 (20.8% - 93.8%)	100% 18/18 (82.4% - 100%)
Patients with recurrent symptoms	95.1% 328/345 (92.2% - 96.9%)	93.5% 343/367 (90.4% - 95.6%)	94.8% 327/345 (91.9% - 96.7%)	91.8% 334/364 (88.5% - 94.2%)
Patients with intercourse ≤ 24 hours	91.4% 32/35 (77.6% - 97.0%)	91.3% 42/46 (79.7% - 96.6%)	91.2% 31/34 (77.0% - 97.0%)	95.6% 44/46 (85.5% - 98.8%)

Candida group Performance Results

As presented in [Table 9](#), sensitivity of the Candida group target is stratified by each of the four species that are detected in the Candida group target (*C. albicans*, *C. tropicalis*, *C. parapsilosis*, and *C. dubliniensis*) as identified by the reference method.

Table 9. Candida group Sensitivity by Species

Species	Clinician-collected (CVS)	Self-collected (SVS)
	Sensitivity (95% CI)	
<i>Candida albicans</i>	98.4% 371/377 (96.6% - 99.3%)	97.9% 368/376 (95.9% - 98.9%)
Co-infection <i>Candida albicans</i> and <i>Candida glabrata</i>	100% 6/6 (61.0% - 100%)	100% 6/6 (61.0% - 100%)



Species	Clinician-collected (CVS)	Self-collected (SVS)
	Sensitivity (95% CI)	
Co-infection <i>Candida albicans</i> and <i>Candida krusei</i>	100% 1/1 (20.6% - 100%)	100% 1/1 (20.6% - 100%)
Co-infection <i>Candida albicans</i> and <i>Candida parapsilosis</i>	100% 1/1 (20.6% - 100%)	100.0% 1/1 (20.6% - 100%)
Co-infection <i>Candida albicans</i> and other yeast	80.0% 4/5 (37.5% - 96.4%)	60.0% 3/5 (23.1% - 88.2%)
<i>Candida dubliniensis</i>	100% 5/5 (56.5% - 100%)	100% 5/5 (56.5% - 100%)
<i>Candida parapsilosis</i>	80.0% 4/5 (37.5% - 96.4%)	100.0% 5/5 (56.5% - 100%)
<i>Candida tropicalis</i>	100% 4/4 (51.0% - 100%)	100% 4/4 (51.0% - 100%)
Overall	98.0% 396/404 (96.1% - 99.0%)	97.5% 393/403 (95.5% - 98.7%)

As presented in [Table 10](#), performance of the *Candida* group target stratified by age groups showed sensitivity and specificity of 91.5% or higher across all age groups and specimen collection types.

Table 10. *Candida* group Performance by Age Group

Age Group	Clinician-collected (CVS)		Self-collected (SVS)	
	Sensitivity (95% CI)	Specificity (95% CI)	Sensitivity (95% CI)	Specificity (95% CI)
14–17	100% 2/2 (34.2% - 100%)	N/A	100% 2/2 (34.2% - 100%)	N/A
18–29	98.2% 225/229 (95.6% - 99.3%)	93.9% 308/328 (90.8% - 96.0%)	97.4% 222/228 (94.4% - 98.8%)	91.5% 300/328 (87.9% - 94.0%)
30–39	99.0% 100/101 (94.6% - 99.8%)	93.8% 273/291 (90.4% - 96.0%)	96.0% 97/101 (90.3% - 98.4%)	91.8% 269/293 (88.1% - 94.4%)
40–49	97.9% 47/48 (89.1% - 99.6%)	94.5% 172/182 (90.2% - 97.0%)	100% 48/48 (92.6% - 100%)	91.7% 165/180 (86.7% - 94.9%)
≥ 50	91.7% 22/24 (74.2% - 97.7%)	96.6% 231/239 (93.5% - 98.3%)	100% 24/24 (86.2% - 100%)	93.6% 220/235 (89.7% - 96.1%)

Performance of the *Candida* group target stratified by race and ethnicity subgroups showed sensitivity of >



97.0% and specificity of > 88.0% in all subgroups except in Asian patients in CVS and SVS specimen collection types (Table 11).

Table 11. Candida group Performance by Race and Ethnicity

Race/Ethnicity	Clinician-collected (CVS)		Self-collected (SVS)	
	Sensitivity (95% CI)	Specificity (95% CI)	Sensitivity (95% CI)	Specificity (95% CI)
White	97.2% 209/215 (94.0% - 98.7%)	95.6% 570/596 (93.7% - 97.0%)	98.2% 212/216 (95.3% - 99.3%)	92.8% 553/596 (90.4% - 94.6%)
Black or African American	98.8% 170/172 (95.9% - 99.7%)	93.2% 370/397 (90.3% - 95.3%)	97.1% 167/172 (93.4% - 98.8%)	91.1% 359/394 (87.9% - 93.5%)
Asian	100% 5/5 (56.5% - 100%)	88.2% 15/17 (65.7% - 96.7%)	80.0% 4/5 (37.5% - 96.4%)	87.5% 14/16 (64.0% - 96.5%)
American Indian or Alaska Native	100% 2/2 (34.2% - 100%)	88.9% 8/9 (56.5% - 98.0%)	100% 2/2 (34.2% - 100%)	88.9% 8/9 (56.5% - 98.0%)
Native Hawaiian or Other Pacific Islander	N/A	100% 3/3 (43.9% - 100%)	N/A	100% 3/3 (43.9% - 100%)
Mixed/Unknown	100% 10/10 (72.2% - 100%)	100% 18/18 (82.4% - 100%)	100% 8/8 (67.6% - 100%)	94.4% 17/18 (74.2% - 99.0%)
Hispanic or Latino	98.5% 66/67 (92.0% - 99.7%)	96.1% 146/152 (91.7% - 98.2%)	98.5% 65/66 (91.9% - 99.7%)	92.8% 142/153 (87.6% - 95.9%)

Performance of the Candida group target in subgroups based on clinical conditions at the time of specimen collection is presented in Table 12. Results showed sensitivity and specificity ranging from 82.1% to 100% in CVS and SVS specimen collection types.

Table 12. Candida group Performance by Clinical Condition

Clinical Condition	Clinician-collected (CVS)		Self-collected (SVS)	
	Sensitivity (95% CI)	Specificity (95% CI)	Sensitivity (95% CI)	Specificity (95% CI)
Pregnant patients	98.0% 49/50 (89.5% - 99.7%)	92.5% 49/53 (82.1% - 97.0%)	95.9% 47/49 (86.3% - 98.9%)	94.3% 50/53 (84.6% - 98.1%)
Patients with menses at enrollment	100% 20/20 (83.9% - 100%)	97.2% 70/72 (90.4% - 99.2%)	100% 20/20 (83.9% - 100%)	92.9% 65/70 (84.3% - 96.9%)



Clinical Condition	Clinician-collected (CVS)		Self-collected (SVS)	
	Sensitivity (95% CI)	Specificity (95% CI)	Sensitivity (95% CI)	Specificity (95% CI)
Patients using anti-fungals ≤ 24 hours	100% 23/23 (85.7% - 100%)	82.1% 23/28 (64.4% - 92.1%)	95.5% 21/22 (78.2% - 99.2%)	82.1% 23/28 (64.4% - 92.1%)
Patients using antibiotics ≤ 24 hours	100% 9/9 (70.1% - 100%)	86.7% 13/15 (62.1% - 96.3%)	100% 9/9 (70.1% - 100%)	86.7% 13/15 (62.1% - 96.3%)
Patients using estrogen therapy ≤ 24 hours	83.3% 5/6 (43.6% - 97.0%)	100% 15/15 (79.6% - 100%)	100% 6/6 (61.0% - 100%)	100% 15/15 (79.6% - 100%)
Patient with recurrent symptoms	98.1% 210/214 (95.3% - 99.3%)	96.1% 491/511 (94.0% - 97.4%)	97.2% 205/211 (93.9% - 98.7%)	92.0% 470/511 (89.3% - 94.0%)
Patient with intercourse ≤ 24 hours	100% 24/24 (86.2% - 100%)	96.6% 57/59 (88.5% - 99.1%)	100% 25/25 (86.7% - 100%)	94.7% 54/57 (85.6% - 98.2%)

Candida glab-krus Performance Results

Performance of the Candida glab-krus target was evaluated in fresh and contrived specimens. [Table 13](#) presents sensitivity of the Candida glab-krus target from fresh perspective specimens stratified by *C. glabrata* and *C. krusei*.

Table 13. Candida glab-krus Sensitivity in Fresh Specimens by Species

Species	Clinician-collected (CVS)	Self-collected (SVS)
	Sensitivity (95% CI)	
<i>Candida glabrata</i>	95.5% 42/44 (84.9% - 98.7%)	97.7% 42/43 (87.9% - 99.6%)
<i>Candida krusei</i>	66.7% 2/3 (20.8% - 93.8%)	100% 3/3 (43.9% - 100%)
Overall	93.6% 44/47 ^a (82.8% - 97.8%)	97.8% 45/46 ^b (88.7% - 99.6%)

a. Testing results with an FDA-cleared NAAT: 2 were also positive and 1 was negative.

b. Testing results with an FDA-cleared NAAT: 1 was negative.

[Table 14](#) presents a summary of performance of the Candida glab-krus target in contrived specimens, including the concentrations that were tested as well as the number of replicates tested at each concentration.

**Table 14. Performance of *Candida glab-krus* in Contrived Specimens**

Contrived Specimen	Load (× LoD)	Concentration (CFU/mL)	N of Replicates Tested	Evaluable Results N = 127	
				PPA (95% CI)	NPA (95% CI)
<i>Candida glabrata</i>	Low (1.8×)	36	25	96.0% 24/25 ^a (80.5% - 99.3%)	N/A
	Moderate (9.5×)	190	20	100% 20/20 (83.9% - 100%)	N/A
	High (19×)	380	5	100% 5/5 (56.5% - 100%)	N/A
<i>Candida krusei</i>	Low (1.8×)	1,181	25	100.0% 25/25 (86.7% - 100.0%)	N/A
	Moderate (8.5×)	5,576	20	100.0% 20/20 (83.9% - 100%)	N/A
	High (19×)	12,464	5 ^b	100% 4/4 (51.0% - 100%)	N/A
Negative	N/A	N/A	30 ^c	N/A	96.4% 27/28 ^d (82.3% - 99.4%)
Total			130 ^e	99.0% 98/99 (89.5% - 99.6%)	96.4% 27/28 (82.3% - 99.4%)

- One false negative was a low positive specimen prepared at 1.8× LoD.
- A total of five specimens were tested. Four specimens gave valid results and were included in the calculation. One specimen was not included in the calculation due to a final non-determinate result.
- A total of 30 specimens were tested. 28 specimens gave valid results and were included in the calculation. Two specimens were not included in the calculation due to a final non-determinate result.
- One false positive was detected at a Ct value of 39.3.
- Of the 130 tested contrived specimens, three gave initial non-determinate results. Two of the three (2/3) specimens were retested and generated final non-determinate results. One of the three (1/3) specimens was not retested. Both the initial and final non-determinate rates were 2.3% (3/130).

As presented in [Table 15](#), performance of the *Candida glab-krus* target stratified by age groups showed sensitivity of 81.8% or higher and specificity of 98.6% or higher across all age groups and specimen collection types.

**Table 15. Candida glab-krus Performance by Age Group**

Age Group	Clinician-collected (CVS)		Self-collected (SVS)	
	Sensitivity (95% CI)	Sensitivity (95% CI)	Sensitivity (95% CI)	Sensitivity (95% CI)
14–17	N/A	100% 2/2 (34.2% - 100%)	N/A	100% 2/2 (34.2% - 100%)
18–29	81.8% 9/11 (52.3% - 94.9%)	99.6% 544/546 (98.7% - 99.9%)	100% 10/10 (72.2% - 100%)	100% 546/546 (99.3% - 100%)
30–39	90.9% 10/11 (62.3% - 98.4%)	100% 381/381 (99.0% - 100%)	90.9% 10/11 (62.3% - 98.4%)	99.0% 379/383 (97.4% - 99.6%)
40–49	100% 9/9 (70.1% - 100%)	99.6% 220/221 (97.5% - 99.9%)	100% 9/9 (70.1% - 100%)	98.6% 216/219 (96.0% - 99.5%)
≥ 50	100% 16/16 (80.6% - 100%)	99.2% 245/247 (97.1% - 99.8%)	100% 16/16 (80.6% - 100%)	99.2% 241/243 (97.0% - 99.8%)

Performance of the Candida glab-krus target stratified by race and ethnicity subgroups showed sensitivity ranging from 91.7% to 100% and specificity ranging from 99.2% to 100% in CVS and SVS specimen collection types (Table 16).

Table 16. Candida glab-krus Performance by Race and Ethnicity

Race/Ethnicity	Clinician-collected (CVS)		Self-collected (SVS)	
	Sensitivity (95% CI)	Sensitivity (95% CI)	Sensitivity (95% CI)	Sensitivity (95% CI)
White	91.7% 22/24 (74.2% - 97.7%)	99.6% 784/787 (98.9% - 99.9%)	100% 24/24 (86.2% - 100%)	99.2% 782/788 (98.4% - 99.7%)
Black or African American	95.5% 21/22 (78.2% - 99.2%)	99.6% 545/547 (98.7% - 99.9%)	95.2% 20/21 (77.3% - 99.2%)	99.5% 542/545 (98.4% - 99.8%)
Asian	N/A	100% 22/22 (85.1% - 100%)	N/A	100% 21/21 (84.5% - 100%)
American Indian or Alaska Native	N/A	100% 11/11 (74.1% - 100%)	N/A	100% 11/11 (74.1% - 100%)
Native Hawaiian or Other Pacific Islander	N/A	100% 3/3 (43.9% - 100%)	N/A	100% 3/3 (43.9% - 100%)



Race/Ethnicity	Clinician-collected (CVS)		Self-collected (SVS)	
	Sensitivity (95% CI)	Sensitivity (95% CI)	Sensitivity (95% CI)	Sensitivity (95% CI)
Mixed/Unknown	100% 1/1 (20.6% - 100%)	100% 27/27 (87.5% - 100%)	100% 1/1 (20.6% - 100%)	100% 25/25 (86.7% - 100%)
Hispanic or Latino	100% 7/7 (64.6% - 100%)	100% 212/212 (98.2% - 100%)	100% 7/7 (64.6% - 100%)	100% 212/212 (98.2% - 100%)

Performance of the *Candida glab-krus* target in subgroups based on clinical conditions at the time of specimen collection is presented in [Table 17](#). Results showed sensitivity and specificity ranging from 75.0% to 100% in CVS and SVS specimen collection types.

Table 17. *Candida glab-krus* Performance by Clinical Condition

Clinical Condition	Clinician-collected (CVS)		Self-collected (SVS)	
	Sensitivity (95% CI)	Sensitivity (95% CI)	Sensitivity (95% CI)	Sensitivity (95% CI)
Pregnant patients	100% 1/1 (20.6% - 100%)	100% 102/102 (96.4% - 100%)	100% 1/1 (20.6% - 100%)	99.0% 100/101 (94.6% - 99.8%)
Patients with menses at enrollment	80.0% 4/5 (37.5% - 96.4%)	100% 87/87 (95.8% - 100%)	75.0% 3/4 (30.1% - 95.4%)	100% 86/86 (95.7% - 100%)
Patients using anti-fungals ≤ 24 hours	N/A	100% 51/51 (93.0% - 100%)	N/A	100% 50/50 (92.9% - 100%)
Patients using antibiotics ≤ 24 hours	100% 1/1 (20.6% - 100%)	100% 23/23 (85.7% - 100%)	100% 1/1 (20.6% - 100%)	100% 23/23 (85.7% - 100%)
Patients using estrogen therapy ≤ 24 hours	N/A	100% 21/21 (84.5% - 100%)	N/A	100% 21/21 (84.5% - 100%)
Patient with recurrent symptoms	100% 24/24 (86.2% - 100%)	99.4% 697/701 (98.5% - 99.8%)	100% 23/23 (85.7% - 100%)	99.1% 693/699 (98.1% - 99.6%)
Patient with intercourse ≤ 24 hours	100% 2/2 (34.2% - 100%)	97.5% 79/81 (91.4% - 99.3%)	100% 2/2 (34.2% - 100%)	98.8% 79/80 (93.2% - 99.8%)

TV Performance Results

As presented in [Table 18](#), performance of the TV target stratified by age groups showed PPA and NPA of



93.8% or higher across all age groups and specimen collection types.

Table 18. TV Performance by Age Group

Age Group	Clinician-collected (CVS)		Self-collected (SVS)	
	PPA (95% CI)	NPA (95% CI)	PPA (95% CI)	NPA (95% CI)
14–17	N/A	100% 2/2 (34.2% - 100%)	N/A	100% 2/2 (34.2% - 100%)
18–29	96.2% 25/26 (81.1% - 99.3%)	99.8% 512/513 (98.9% - 100%)	96.2% 25/26 (81.1% - 99.3%)	100% 512/512 (99.3% - 100%)
30–39	100% 26/26 (87.1% - 100%)	99.4% 353/355 (98.0% - 99.9%)	100% 26/26 (87.1% - 100%)	99.4% 355/357 (98.0% - 99.9%)
40–49	94.1% 16/17 (73.0% - 99.0%)	99.5% 211/212 (97.4% - 99.9%)	93.8% 15/16 (71.7% - 98.9%)	100% 211/211 (98.2% - 100%)
≥ 50	100% 6/6 (61.0% - 100%)	99.6% 254/255 (97.8% - 99.9%)	100% 6/6 (61.0% - 100%)	99.6% 250/251 (97.8% - 99.9%)

Performance of the TV target stratified by race and ethnicity subgroups showed PPA ranging from 83.3% to 100% and NPA ranging from 99.2% to 100% in CVS and SVS specimen collection types (Table 19).

Table 19. TV Performance by Race and Ethnicity

Race/Ethnicity	Clinician-collected (CVS)		Self-collected (SVS)	
	PPA (95% CI)	NPA (95% CI)	PPA (95% CI)	NPA (95% CI)
White	93.3% 14/15 (70.2% - 98.8%)	99.9% 775/776 (99.3% - 100%)	93.3% 14/15 (70.2% - 98.8%)	100% 777/777 (99.5% - 100%)
Black or African American	98.3% 58/59 (91.0% - 99.7%)	99.2% 497/501 (98.0% - 99.7%)	98.3% 57/58 (90.9% - 99.7%)	99.4% 496/499 (98.2% - 99.8%)
Asian	N/A	100% 21/21 (84.5% - 100%)	N/A	100% 20/20 (83.9% - 100%)
American Indian or Alaska Native	100% 1/1 (20.6% - 100%)	100% 10/10 (72.2% - 100%)	100% 1/1 (20.6% - 100%)	100% 10/10 (72.2% - 100%)
Native Hawaiian or Other Pacific Islander	N/A	100% 3/3 (43.9% - 100%)	N/A	100% 3/3 (43.9% - 100%)



Race/Ethnicity	Clinician-collected (CVS)		Self-collected (SVS)	
	PPA (95% CI)	NPA (95% CI)	PPA (95% CI)	NPA (95% CI)
Mixed/Unknown	N/A	100% 26/26 (87.1% - 100%)	N/A	100% 24/24 (86.2% - 100%)
Hispanic or Latino	83.3% 5/6 (43.6% - 97.0%)	100% 205/205 (98.2% - 100%)	83.3% 5/6 (43.6% - 97.0%)	100% 205/205 (98.2% - 100%)

Performance of the TV target in subgroups based on clinical conditions at the time of specimen collection is presented in [Table 20](#). Results showed PPA ranging from 85.7% to 100% and NPA ranging from 97.9% to 100% in most subgroups in CVS and SVS specimen collection types.

Table 20. TV Performance by Clinical Condition

Clinical Condition	Clinician-collected (CVS)		Self-collected (SVS)	
	PPA (95% CI)	NPA (95% CI)	PPA (95% CI)	NPA (95% CI)
Pregnant patients	100% 3/3 (43.9% - 100%)	100% 94/94 (96.1% - 100%)	100% 3/3 (43.9% - 100%)	100% 93/93 (96.0% - 100%)
Patients with menses at enrollment	85.7% 6/7 (48.7% - 97.4%)	100% 81/81 (95.5% - 100%)	85.7% 6/7 (48.7% - 97.4%)	100% 79/79 (95.4% - 100%)
Patients using anti-fungals ≤ 24 hours	100% 2/2 (34.2% - 100%)	98.0% 48/49 (89.3% - 99.6%)	100% 2/2 (34.2% - 100%)	97.9% 47/48 (89.1% - 99.6%)
Patients using antibiotics ≤ 24 hours	0% 0/1 (0% - 79.3%)	100% 22/22 (85.1% - 100%)	0% 0/1 (0% - 79.3%)	100% 22/22 (85.1% - 100%)
Patients using estrogen therapy ≤ 24 hours	N/A	100% 21/21 (84.5% - 100%)	N/A	100% 21/21 (84.5% - 100%)
Patient with recurrent symptoms	97.8% 45/46 (88.7% - 99.6%)	99.4% 653/657 (98.4% - 99.8%)	97.8% 44/45 (88.4% - 99.6%)	99.5% 652/655 (98.7% - 99.8%)
Patient with intercourse ≤ 24 hours	100% 5/5 (56.5% - 100%)	100% 76/76 (95.2% - 100%)	100% 5/5 (56.5% - 100%)	100% 75/75 (95.1% - 100%)

Multi-Target Detection

Rates of multi-target detection for the Xpert Xpress MVP test are presented in [Table 21](#), which includes specimens with valid results in all four targets of the Xpert Xpress MVP test and by the reference/comparator method (1,433 of 1,473 total CVS specimens, and 1,428 of 1,474 total SVS specimens). Overall, 17.4% of CVS specimens and 18.4% SVS specimens resulted in positive results for more than one target in the Xpert Xpress MVP test. The most prevalent multi-target detection in both CVS and SVS specimens was a combination of BV and Candida group (11.2% and 11.8%, respectively), followed by a combination of BV and TV (3.6% and 3.6%, respectively).

**Table 21. Rates of Multi-Target Detection by Xpert Xpress MVP**

Analytes Detected	Clinician-collected (CVS)	Self-collected (SVS)
BV, Candida group	11.2% 161/1433	11.8% 169/1428
BV, TV	3.6% 52/1433	3.6% 52/1428
BV, Candida group, TV	0.9% 13/1433	0.8% 12/1428
BV, Candida glab-krus	0.5% 7/1433	0.5% 7/1428
Candida group, Candida glab-krus	0.3% 5/1433	0.6% 8/1428
BV, Candida group, Candida glab-krus	0.3% 5/1433	0.7% 10/1428
Candida group, TV	0.3% 4/1433	0.3% 4/1428
Candida glab-krus, TV	0.1% 1/1433	0.1% 1/1428
Candida group, Candida glab-krus, TV	0.1% 1/1433	N/A
Total	17.4% 249/1433	18.4% 263/1428

The number of fresh specimens with positive results for more than one target as determined by the Xpert Xpress MVP test or reference/comparator methods are summarized in [Table 22](#), where bolded values indicate concordant results and non-bolded values indicate discordant results.

Among 1,433 CVS specimens, 191 specimens yielded multi-target concordant results between Xpert Xpress MVP and reference methods. Of the 191 specimens, 66.0% (126/191) had concordant BV and Candida group co-infections, and 23.6% (45/191) had concordant BV and TV co-infections. Among 1,428 SVS specimens, 183 specimens yielded multi-target concordant results. Of the 183 specimens, 65.0% (119/183) had concordant BV and Candida group co-infections, and 24.0% (44/183) had concordant BV and TV co-infections.

Table 22. Multi-Target Detection by the Xpert Xpress MVP Test

	Total Number of Occurrences between the Xpert Xpress MVP Test vs. Reference/Comparator Method (CVS/SVS)													
	Infections	BV	BV, Candida group	BV, Candida glab- krus	BV, Candida group, Candida glab-krus	BV, TV	BV, Candida group, TV	Candida group	Candida group, Candida glab-krus	Candida group, TV	Candida glab- krus	Candida glab- krus, TV	TV	Negative
The Xpert Xpress MVP Test	BV		0/5	-	-	-	-	1/0	-	-	-	-	-	26/28
	BV, Candida group	16/ 26	126/119	-	1/0	-	-	16/22	1/0	-	-	-	-	1/2



Total Number of Occurrences between the Xpert Xpress MVP Test vs. Reference/Comparator Method (CVS/SVS)													
Infections	BV	BV, Candida group	BV, Candida glab-krus	BV, Candida group, Candida glab-krus	BV, TV	BV, Candida group, TV	Candida group	Candida group, Candida glab-krus	Candida group, TV	Candida glab-krus	Candida glab-krus, TV	TV	Negative
BV, Candida glab-krus	2/3	-	3/1	-	-	-	-	-	-	2/3	-	-	-
BV, Candida group, Candida glab-krus	0/1	-	0/2	4/5	-	-	-	0/1	-	1/1	-	-	-
BV, TV	2/2	-	-	-	45/44	1/1	-	-	-	-	-	4/5	-
BV, Candida group, TV	-	-	-	-	3/3	9/9	-	-	1/0	-	-	-	-
Candida group	1/2	14/15	-	-	-	-	-	-	1/1	1/1	-	-	27/36
Candida group, Candida glab-krus	-	-	1/1	-	-	-	-	1/1	-	3/6	-	-	-
Candida group, TV	-	-	-	-	-	-	1/0	-	2/3	-	-	-	1/1
Candida group, Candida glab-krus, TV	-	-	-	-	-	-	-	-	-	1/0	-	-	-
Candida glab-krus	-	-	1/0	-	-	-	-	-	-	-	-	-	3/5
Candida glab-krus, TV	-	-	-	-	-	-	-	-	-	-	1/1	-	-
TV	-	-	-	-	1/1	-	-	-	-	-	-	-	-
Negative	17/15	-	-	-	-	-	6/4	-	-	-	-	1/1	-

Non-Determinate Rate

Of the 2,947 Xpert Xpress MVP runs performed in the clinical study, 130 resulted in non-determinate (**Error, Invalid or No Results**) results on first attempt. Upon retest of these 130 specimens, 22 remained non-determinate. The initial non-determinate rate was 4.4% (130/2947) and the overall non-determinate rate was 0.7% (22/2947).

The initial non-determinate rate for CVS specimens was 3.9% (58/1473) and the overall non-determinate rate was 0.5% (8/1473). The initial non-determinate rate for SVS specimens was 4.9% (72/1474) and the overall non-determinate rate was 0.9% (14/1474).



Analytical Performance

Analytical Sensitivity (Limit of Detection)

The analytical sensitivity of the Xpert Xpress MVP test was determined by preparing dilutions for each of the target organisms detected by the test. The near cut-off concentrations for the BV organisms were also determined. Positive samples were prepared by inoculating simulated vaginal swab matrix with each representative strain or quantified stocks of plasmid DNA containing the cloned genomic targets of BVAB2 or *Megasphaera-1*. Replicates of 20 were evaluated at a minimum of five concentrations for each of the target organisms. The limit of detection (LoD) and near cut-off concentrations for the target organisms were estimated by probit analysis. The LoD is defined as the lowest concentration of organism sample that can be reproducibly distinguished from negative samples with 95% confidence. The near cut-off concentration for the BV organisms is defined as the lowest concentrations of *Atopobium vaginae* and *Megasphaera-1*, or *A. vaginae* and BVAB2, or *A. vaginae* and *Megasphaera-1* and BVAB2, or *A. vaginae* in the absence of *Megasphaera-1* and BVAB2 that result in BV POSITIVE test results and can be reproducibly distinguished from negative samples with a 95% confidence level. The LoD for each *Candida* spp. and *Trichomonas vaginalis* strain was confirmed in natural clinical vaginal swab matrix and simulated vaginal swab matrix (Table 23). The LoD and near cut-off concentrations for each BV organism were confirmed in simulated vaginal swab matrix (Table 23 and Table 24).

Table 23. Limit of Detection of BV, Candida group, Candida glab-krus, and TV Targets for Xpert Xpress MVP

Target	Strain	LoD	Units
BV	<i>Atopobium vaginae</i> ATCC BAA-55	32	CFU/mL
	<i>Megasphaera-1</i> plasmid DNA	338	copies/mL
	BVAB2 plasmid DNA	50	copies/mL
Candida group	<i>Candida albicans</i> ATCC 32032	30	CFU/mL
	<i>Candida dubliniensis</i> ATCC 44508	1,316	CFU/mL
	<i>Candida tropicalis</i> ATCC 13803	750	CFU/mL
	<i>Candida parapsilosis</i> ATCC 22019	1,339	CFU/mL
Candida glab-krus	<i>Candida glabrata</i> ATCC 28482	20	CFU/mL
	<i>Candida krusei</i> ATCC 34135	656	CFU/mL
TV	<i>Trichomonas vaginalis</i> ATCC 30001	5	cells/mL

Table 24. Near Cut-off Concentration of BV Target for Xpert Xpress MVP

Target	Strain	Near Cut-off concentration	Units
BV	<i>Atopobium vaginae</i> ATCC BAA-55 (in the absence of <i>Megasphaera-1</i> and BVAB2)	320,000	CFU/mL
	<i>Atopobium vaginae</i> ATCC BAA-55 (in the presence of <i>Megasphaera-1</i> and BVAB2)	2,750	CFU/mL
	<i>Megasphaera-1</i> plasmid DNA	390	copies/mL
	BVAB2 plasmid DNA	50	copies/mL



Analytical Reactivity (Inclusivity)

The analytical reactivity (inclusivity) of the Xpert Xpress MVP test was determined with 5 strains of *Candida albicans*, 5 strains of *C. dubliniensis*, 5 strains of *C. tropicalis*, 5 strains of *C. parapsilosis*, 5 strains of *C. glabrata*, 5 strains of *C. krusei*, 11 strains of *Atopobium* spp. (*Atopobium vaginae* and/or *Atopobium* novel species CCUG 55226), and 10 strains of *Trichomonas vaginalis* that were diluted in simulated vaginal swab matrix at 3× LoD. Each *Atopobium* spp. strain was also evaluated at 3× near cut-off concentrations diluted in simulated vaginal swab matrix in the absence or presence of BVAB2 and/or *Megasphaera*-1 DNA to confirm the correct **BV POSITIVE** test results were reported. Three replicates were tested for each strain.

The Xpert Xpress MVP test correctly identified 46 of 51 strains upon initial testing at 3× LoD. Two strains of *Atopobium vaginae* tested at 3× LoD and three strains of *Candida albicans* tested at 3× LoD were not detected and were tested at higher concentrations to determine the minimum concentration sufficient for detection. One *A. vaginae* strain was detected at ~4× LoD and the other strain was detected at ~12× LoD. One *C. albicans* strain was detected at ~4× LoD and the other two *C. albicans* strains were detected at ~20× LoD. For near cut-off concentration of *Atopobium* spp. in the absence of *Megasphaera*-1 and BVAB2, the Xpert Xpress MVP test correctly reported **BV POSITIVE** test result for 7 of the 11 strains upon initial testing at 3× near cut-off concentration. Four strains did not meet acceptance criteria and were further tested to determine the minimum concentration sufficient for reporting **BV POSITIVE** test result. One *Atopobium* spp. strain reported **BV POSITIVE** at ~4×, two strains at ~6×, and one strain at ~12× near cut-off concentration. For the near cut-off concentration of *Atopobium* spp. in the presence of *Megasphaera*-1 and/or BVAB2, the Xpert Xpress MVP test correctly reported **BV POSITIVE** test result for 7 of the 11 strains upon initial testing at 3× near cut-off concentration. Four strains did not meet acceptance criteria and were further tested to determine the minimum concentration sufficient for reporting **BV POSITIVE** test result. Two *Atopobium* spp. strains reported **BV POSITIVE** at ~4×, one strain at ~6×, and one strain at ~7× near cut-off concentration. The inclusivity result summary is presented in [Table 25](#).

Table 25. Analytical Reactivity (Inclusivity) of the Xpert Xpress MVP test

Organism	Strain	Concentration	Result			
			BV	Candida group	Candida glab-krus	TV
Negative Control			Negative	Not Detected	Not Detected	Not Detected
<i>Atopobium</i> spp. LoD (Below the near cut-off concentrations and not generating BV POSITIVE result) ^a	CCUG 39382	96 CFU/mL	pos ^a	Not Detected	Not Detected	Not Detected
	CCUG 42099	96 CFU/mL	pos ^a	Not Detected	Not Detected	Not Detected
	CCUG 43049	96 CFU/mL	pos ^a	Not Detected	Not Detected	Not Detected
	CCUG 44061	96 CFU/mL	pos ^a	Not Detected	Not Detected	Not Detected
	CCUG 44116	96 CFU/mL	pos ^a	Not Detected	Not Detected	Not Detected
	CCUG 44125	120 CFU/mL ^b	pos ^a	Not Detected	Not Detected	Not Detected
	CCUG 44156	96 CFU/mL	pos ^a	Not Detected	Not Detected	Not Detected
	CCUG 44258	96 CFU/mL	pos ^a	Not Detected	Not Detected	Not Detected
	CCUG 48515	400 CFU/mL ^c	pos ^a	Not Detected	Not Detected	Not Detected



Organism	Strain	Concentration	Result			
			BV	Candida group	Candida glab-krus	TV
	CCUG 55227	96 CFU/mL	pos ^a	Not Detected	Not Detected	Not Detected
	CCUG 55226	96 CFU/mL	pos ^a	Not Detected	Not Detected	Not Detected
<i>Atopobium</i> spp. In the absence of <i>Megasphaera</i> -1 and BVAB2	CCUG 39382	9.6×10 ⁵ CFU/mL	Positive	Not Detected	Not Detected	Not Detected
	CCUG 42099	9.6×10 ⁵ CFU/mL	Positive	Not Detected	Not Detected	Not Detected
	CCUG 43049	9.6×10 ⁵ CFU/mL	Positive	Not Detected	Not Detected	Not Detected
	CCUG 44061	9.6×10 ⁵ CFU/mL	Positive	Not Detected	Not Detected	Not Detected
	CCUG 44116	9.6×10 ⁵ CFU/mL	Positive	Not Detected	Not Detected	Not Detected
	CCUG 44125	1.2×10 ⁶ CFU/mL ^d	Positive	Not Detected	Not Detected	Not Detected
	CCUG 44156	2.0×10 ⁶ CFU/mL ^e	Positive	Not Detected	Not Detected	Not Detected
	CCUG 44258	9.6×10 ⁵ CFU/mL	Positive	Not Detected	Not Detected	Not Detected
	CCUG 48515	4.0×10 ⁶ CFU/mL ^f	Positive	Not Detected	Not Detected	Not Detected
	CCUG 55227	9.6×10 ⁵ CFU/mL	Positive	Not Detected	Not Detected	Not Detected
	CCUG 55226	2.0×10 ⁶ CFU/mL ^g	Positive	Not Detected	Not Detected	Not Detected
<i>Atopobium</i> spp. In the presence of BVAB2	CCUG 39382	8,250 CFU/mL	Positive	Not Detected	Not Detected	Not Detected
	CCUG 42099	8,250 CFU/mL	Positive	Not Detected	Not Detected	Not Detected
	CCUG 43049	8,250 CFU/mL	Positive	Not Detected	Not Detected	Not Detected
	CCUG 44061	8,250 CFU/mL	Positive	Not Detected	Not Detected	Not Detected
	CCUG 44116	8,250 CFU/mL	Positive	Not Detected	Not Detected	Not Detected
	CCUG 44125	10,000 CFU/mL ^h	Positive	Not Detected	Not Detected	Not Detected
	CCUG 44156	17,000 CFU/mL ⁱ	Positive	Not Detected	Not Detected	Not Detected
	CCUG 44258	8,250 CFU/mL	Positive	Not Detected	Not Detected	Not Detected
	CCUG 48515	17,000 CFU/mL ^j	Positive	Not Detected	Not Detected	Not Detected
	CCUG 55227	8,250 CFU/mL	Positive	Not Detected	Not Detected	Not Detected



Organism	Strain	Concentration	Result				
			BV	Candida group	Candida glab-krus	TV	
	CCUG 55226	10,000 CFU/mL ^k	Positive	Not Detected	Not Detected	Not Detected	
<i>Atopobium</i> spp. In the presence of <i>Megasphaera-1</i>	CCUG 39382	8,250 CFU/mL	Positive	Not Detected	Not Detected	Not Detected	
	CCUG 42099	8,250 CFU/mL	Positive	Not Detected	Not Detected	Not Detected	
	CCUG 43049	8,250 CFU/mL	Positive	Not Detected	Not Detected	Not Detected	
	CCUG 44061	8,250 CFU/mL	Positive	Not Detected	Not Detected	Not Detected	
	CCUG 44116	8,250 CFU/mL	Positive	Not Detected	Not Detected	Not Detected	
	CCUG 44125	10,000 CFU/mL ^h	Positive	Not Detected	Not Detected	Not Detected	
	CCUG 44156	17,000 CFU/mL ⁱ	Positive	Not Detected	Not Detected	Not Detected	
	CCUG 44258	8,250 CFU/mL	Positive	Not Detected	Not Detected	Not Detected	
	CCUG 48515	20,000 CFU/mL ^j	Positive	Not Detected	Not Detected	Not Detected	
	CCUG 55227	8,250 CFU/mL	Positive	Not Detected	Not Detected	Not Detected	
	CCUG 55226	10,000 CFU/mL ^k	Positive	Not Detected	Not Detected	Not Detected	
	<i>Atopobium</i> spp. In the presence of <i>Megasphaera-1</i> and BVAB2	CCUG 39382	8,250 CFU/mL	Positive	Not Detected	Not Detected	Not Detected
		CCUG 42099	8,250 CFU/mL	Positive	Not Detected	Not Detected	Not Detected
CCUG 43049		8,250 CFU/mL	Positive	Not Detected	Not Detected	Not Detected	
CCUG 44061		8,250 CFU/mL	Positive	Not Detected	Not Detected	Not Detected	
CCUG 44116		8,250 CFU/mL	Positive	Not Detected	Not Detected	Not Detected	
CCUG 44125		10,000 CFU/mL ^h	Positive	Not Detected	Not Detected	Not Detected	
CCUG 44156		17,000 CFU/mL ⁱ	Positive	Not Detected	Not Detected	Not Detected	
CCUG 44258		8,250 CFU/mL	Positive	Not Detected	Not Detected	Not Detected	
CCUG 48515		17,000 CFU/mL ^j	Positive	Not Detected	Not Detected	Not Detected	
CCUG 55227		8,250 CFU/mL	Positive	Not Detected	Not Detected	Not Detected	
CCUG 55226		10,000 CFU/mL ^k	Positive	Not Detected	Not Detected	Not Detected	



Organism	Strain	Concentration	Result			
			BV	Candida group	Candida glab-krus	TV
<i>Candida albicans</i>	ATCC 38289	120 CFU/mL ^l	Negative	Detected	Not Detected	Not Detected
	ATCC 62376	600 CFU/mL ^m	Negative	Detected	Not Detected	Not Detected
	ATCC 96113	90 CFU/mL	Negative	Detected	Not Detected	Not Detected
	ATCC 60193	90 CFU/mL	Negative	Detected	Not Detected	Not Detected
	ATCC 753	600 CFU/mL ⁿ	Negative	Detected	Not Detected	Not Detected
<i>Candida dubliniensis</i>	ATCC MYA-179	3,948 CFU/mL	Negative	Detected	Not Detected	Not Detected
	ATCC MYA-577	3,948 CFU/mL	Negative	Detected	Not Detected	Not Detected
	ATCC MYA-646	3,948 CFU/mL	Negative	Detected	Not Detected	Not Detected
	ATCC MYA-580	3,948 CFU/mL	Negative	Detected	Not Detected	Not Detected
	ATCC MYA-581	3,948 CFU/mL	Negative	Detected	Not Detected	Not Detected
<i>Candida tropicalis</i>	ATCC 34139	2,250 CFU/mL	Negative	Detected	Not Detected	Not Detected
	ATCC 90874	2,250 CFU/mL	Negative	Detected	Not Detected	Not Detected
	ATCC 204318	2,250 CFU/mL	Negative	Detected	Not Detected	Not Detected
	ATCC MYA-2733	2,250 CFU/mL	Negative	Detected	Not Detected	Not Detected
	ATCC MYA-277	2,250 CFU/mL	Negative	Detected	Not Detected	Not Detected
<i>Candida parapsilosis</i>	ATCC 7330	4,017 CFU/mL	Negative	Detected	Not Detected	Not Detected
	ATCC 60548	4,017 CFU/mL	Negative	Detected	Not Detected	Not Detected
	ATCC 90875	4,017 CFU/mL	Negative	Detected	Not Detected	Not Detected
	ATCC 96139	4,017 CFU/mL	Negative	Detected	Not Detected	Not Detected
	ATCC 96140	4,017 CFU/mL	Negative	Detected	Not Detected	Not Detected
<i>Candida glabrata</i>	ATCC 32312	60 CFU/mL	Negative	Not Detected	Detected	Not Detected
	ATCC 32554	60 CFU/mL	Negative	Not Detected	Detected	Not Detected
	ATCC 15126	60 CFU/mL	Negative	Not Detected	Detected	Not Detected
	ATCC 2001	60 CFU/mL	Negative	Not Detected	Detected	Not Detected



Organism	Strain	Concentration	Result			
			BV	Candida group	Candida glab-krus	TV
	ATCC MYA-276	60 CFU/mL	Negative	Not Detected	Detected	Not Detected
<i>Candida krusei</i>	ATCC 28870	1,968 CFU/mL	Negative	Not Detected	Detected	Not Detected
	ATCC 32672	1,968 CFU/mL	Negative	Not Detected	Detected	Not Detected
	ATCC 90878	1,968 CFU/mL	Negative	Not Detected	Detected	Not Detected
	ATCC 200917	1,968 CFU/mL	Negative	Not Detected	Detected	Not Detected
	ATCC 201748	1,968 CFU/mL	Negative	Not Detected	Detected	Not Detected
<i>Trichomonas vaginalis</i>	ATCC 30184	15 cells/mL	Negative	Not Detected	Not Detected	Detected
	ATCC 30187	15 cells/mL	Negative	Not Detected	Not Detected	Detected
	ATCC 30238 ^o	15 cells/mL	Negative	Not Detected	Not Detected	Detected
	ATCC 30240	15 cells/mL	Negative	Not Detected	Not Detected	Detected
	ATCC 30245	15 cells/mL	Negative	Not Detected	Not Detected	Detected
	ATCC 50139	15 cells/mL	Negative	Not Detected	Not Detected	Detected
	ATCC 50141	15 cells/mL	Negative	Not Detected	Not Detected	Detected
	ATCC 50167	15 cells/mL	Negative	Not Detected	Not Detected	Detected
	ATCC 50183	15 cells/mL	Negative	Not Detected	Not Detected	Detected
	ATCC PRA-95	15 cells/mL	Negative	Not Detected	Not Detected	Detected



- a. The LoD for *Atopobium vaginae* is for information only. All *Atopobium* spp. strains tested at ~3× LoD level reported BV NEGATIVE result calls as expected, as the concentration of *Atopobium* spp. strains tested was below the near cut-off concentration either in the presence or absence of Mega1-BVAB2 target. Replicates reporting Atop gp Ct values of ≤ 40.0 was treated as positive (pos) when *Atopobium* spp. strains were tested at ~ 3× LoD.
- b. *Atopobium vaginae* CCUG 44125 was tested at ~ 4× LoD (120 CFU/mL) to obtain 3 of 3 Atop gp Ct values of ≤ 40.0 results.
- c. *Atopobium vaginae* CCUG 48515 was tested at ~ 12× LoD (400 CFU/mL) to obtain 3 of 3 Atop gp Ct values of ≤ 40.0 results.
- d. *Atopobium vaginae* CCUG 44125 was tested at ~ 4× near cut-off concentration (1.2×10⁶ CFU/mL) in the absence of BVAB2 and *Megasphaera-1* to obtain 3 of 3 BV POSITIVE result calls.
- e. *Atopobium vaginae* CCUG 44156 was tested at ~ 6× near cut-off concentration (2.0×10⁶ CFU/mL) in the absence of BVAB2 and *Megasphaera-1* to obtain 3 of 3 BV POSITIVE result calls.
- f. *Atopobium vaginae* CCUG 48515 was tested at ~ 12× near cut-off concentration (4.0×10⁶ CFU/mL) in the absence of BVAB2 and *Megasphaera-1* to obtain 3 of 3 BV POSITIVE result calls.
- g. *Atopobium* novel species CCUG 55226 was tested at ~ 6× near cut-off concentration (2.0×10⁶ CFU/mL) in the absence of BVAB2 and *Megasphaera-1* to obtain 3 of 3 BV POSITIVE result calls.
- h. *Atopobium vaginae* CCUG 44125 was tested at ~ 4× near cut-off concentration (10,000 CFU/mL) in the presence of BVAB2 and/or *Megasphaera-1* to obtain 3 of 3 BV POSITIVE result calls.
- i. *Atopobium vaginae* CCUG 44156 was tested at ~ 6× near cut-off concentration (17,000 CFU/mL) in the presence of BVAB2 and/or *Megasphaera-1* to obtain 3 of 3 BV POSITIVE result calls.
- j. *Atopobium vaginae* CCUG 48515 was tested at ~ 6× (17,000 CFU/mL) to ~ 7× (20,000 CFU/mL) near cut-off concentration in the presence of BVAB2 and/or *Megasphaera-1* to obtain 3 of 3 BV POSITIVE result calls.
- k. *Atopobium* novel species CCUG 55226 was tested at ~ 4× near cut-off concentration (10,000 CFU/mL) in the presence of BVAB2 and/or *Megasphaera-1* to obtain 3 of 3 BV POSITIVE result calls.
- l. *Candida albicans* ATCC 38289 was tested at ~ 4× LoD (120 CFU/mL) to obtain 3 of 3 Candida group DETECTED result calls.
- m. *Candida albicans* ATCC 62376 was tested at ~ 20× LoD (600 CFU/mL) to obtain 3 of 3 Candida group DETECTED result calls.
- n. *Candida albicans* ATCC 753 was tested at ~ 20× LoD (600 CFU/mL) to obtain 3 of 3 Candida group DETECTED result calls.
- o. metronidazole-resistant strain

Analytical Specificity (Cross-reactivity)

The analytical specificity of the Xpert Xpress MVP test was evaluated by testing a panel of 115 potentially cross-reactive microorganisms that are likely to be found in the vaginal flora/female genital tract. All strains were tested in triplicates in simulated vaginal swab matrix at a concentration of at least 10⁶ CFU/mL, 10⁵ cells/mL, 10⁵ TCID₅₀/mL, or 10⁴ International Unit (IU)/mL. No cross-reactivity was observed for 112 of the 115 microorganisms tested with the Xpert Xpress MVP test at the concentrations listed in [Table 26](#).

Trichomonas tenax and *Pentatrichomonas hominis* tested at 1×10⁵ cells/mL reported **TV DETECTED** with the Xpert Xpress MVP test. *Candida orthopsilosis* tested at 1×10⁶ CFU/mL reported Candida group **DETECTED** with the Xpert Xpress MVP test. All three initially cross-reactive organisms were negative on retest at lower concentrations. The results are presented in [Table 27](#). This is addressed in [Limitations](#).

Table 26. Organisms Tested for Analytical Specificity that Showed No Cross-reactivity

Organism	Concentration	Organism	Concentration
Bacteria		Bacteria	
<i>Acinetobacter baumannii</i>	1×10 ⁶ CFU/mL	<i>Mycoplasma genitalium</i>	1×10 ⁶ CFU/mL
<i>Acinetobacter calcoaceticus</i>	1×10 ⁶ CFU/mL	<i>Mycoplasma hominis</i>	1×10 ⁶ CFU/mL
<i>Actinomyces israelii</i>	1×10 ⁶ CFU/mL	<i>Neisseria gonorrhoeae</i>	1×10 ⁶ CFU/mL
<i>Actinomyces pyogenes</i>	1×10 ⁶ CFU/mL	<i>Olsenella uli</i>	1×10 ⁶ CFU/mL
<i>Aerococcus viridans</i>	1×10 ⁶ CFU/mL	<i>Pantoea agglomerans</i>	1×10 ⁶ CFU/mL
<i>Alcaligenes faecalis</i>	1×10 ⁶ CFU/mL	<i>Peptoniphilus asaccharolyticus</i>	1×10 ⁶ CFU/mL



Organism	Concentration	Organism	Concentration
<i>Anaerococcus tetradius</i>	1×10 ⁶ CFU/mL	<i>Peptoniphilus anaerobius</i>	1×10 ⁶ CFU/mL
<i>Atopobium minutum</i>	1×10 ⁶ CFU/mL	<i>Peptostreptococcus anaerobius</i>	1×10 ⁶ CFU/mL
<i>Atopobium parvulum</i>	1×10 ⁶ CFU/mL	<i>Plesiomonas shigelloides</i>	1×10 ⁶ CFU/mL
<i>Atopobium rimae</i>	1×10 ⁶ CFU/mL	<i>Porphyromonas asaccharolytica</i>	1×10 ⁶ CFU/mL
<i>Bacillus subtilis</i>	1×10 ⁶ CFU/mL	<i>Prevotella bivia</i>	1×10 ⁶ CFU/mL
<i>Bacteroides caccae</i>	1×10 ⁶ CFU/mL	<i>Prevotella melaninogenica</i>	1×10 ⁶ CFU/mL
<i>Bacteroides fragilis</i>	1×10 ⁶ CFU/mL	<i>Prevotella oralis</i>	1×10 ⁶ CFU/mL
<i>Bacteroides stercoris</i>	1×10 ⁶ CFU/mL	<i>Propionibacterium acnes</i>	1×10 ⁶ CFU/mL
<i>Bacteroides ureolyticus</i>	1×10 ⁶ CFU/mL	<i>Proteus mirabilis</i>	1×10 ⁶ CFU/mL
<i>Bifidobacterium adolescentis</i>	1×10 ⁶ CFU/mL	<i>Providencia stuartii</i>	1×10 ⁶ CFU/mL
<i>Bifidobacterium breve</i>	1×10 ⁶ CFU/mL	<i>Pseudomonas aeruginosa</i>	1×10 ⁶ CFU/mL
<i>Bifidobacterium longum</i>	1×10 ⁶ CFU/mL	<i>Salmonella typhimurium</i>	1×10 ⁶ CFU/mL
<i>Brevibacterium linens</i>	1×10 ⁶ CFU/mL	<i>Serratia marcescens</i>	1×10 ⁶ CFU/mL
<i>Burkholderia cepacian</i>	1×10 ⁶ CFU/mL	<i>Shigella flexneri</i>	1×10 ⁶ CFU/mL
BVAB1	1×10 ⁶ copies/mL	<i>Sneathia amnii</i>	1×10 ⁶ CFU/mL
<i>Campylobacter jejuni</i>	1×10 ⁶ CFU/mL	<i>Sneathia sanguinegens</i>	1×10 ⁶ CFU/mL
<i>Chlamydia trachomatis</i>	1×10 ⁶ CFU/mL	<i>Staphylococcus aureus</i>	1×10 ⁶ CFU/mL
<i>Citrobacter freundii</i>	1×10 ⁶ CFU/mL	<i>Staphylococcus epidermidis</i>	1×10 ⁶ CFU/mL
<i>Clostridium perfringens</i>	1×10 ⁶ CFU/mL	<i>Streptococcus agalactiae</i>	1×10 ⁶ CFU/mL
<i>Corynebacterium genitalium</i>	1×10 ⁶ CFU/mL	<i>Streptococcus mitis</i>	1×10 ⁶ CFU/mL
<i>Dialister microaerophilus</i>	1×10 ⁶ CFU/mL	<i>Streptococcus mutans</i>	1×10 ⁶ CFU/mL
<i>Eikenella corrodens</i>	1×10 ⁶ CFU/mL	<i>Streptococcus salivarius</i>	1×10 ⁶ CFU/mL
<i>Enterobacter aerogenes</i>	1×10 ⁶ CFU/mL	<i>Treponema pallidum</i>	1×10 ⁶ copies/mL
<i>Enterococcus faecalis</i>	1×10 ⁶ CFU/mL	<i>Veillonella atypica</i>	1×10 ⁶ CFU/mL
<i>Enterococcus faecium</i>	1×10 ⁶ CFU/mL	<i>Veillonella parvula</i>	1×10 ⁶ CFU/mL
<i>Erysipelothrix rhusiopathiae</i>	1×10 ⁶ CFU/mL	<i>Vibrio parahaemolyticus</i>	1×10 ⁶ CFU/mL
<i>Escherichia coli</i>	1×10 ⁶ CFU/mL	<i>Yersinia enterocolitica</i>	1×10 ⁶ CFU/mL
<i>Fingoldia magna</i>	1×10 ⁶ CFU/mL	Yeasts	
<i>Fusobacterium nucleatum</i>	1×10 ⁶ CFU/mL	<i>Candida catenulate</i>	1×10 ⁶ CFU/mL
<i>Gardnerella vaginalis</i>	1×10 ⁶ CFU/mL	<i>Candida famata</i>	1×10 ⁶ CFU/mL
<i>Gemella haemolysans</i>	1×10 ⁶ CFU/mL	<i>Candida haemulonii</i>	1×10 ⁶ CFU/mL
<i>Kingella denitrificans</i>	1×10 ⁶ CFU/mL	<i>Candida inconspicua</i>	1×10 ⁶ CFU/mL
<i>Klebsiella pneumoniae</i>	1×10 ⁶ CFU/mL	<i>Candida intermedia</i>	1×10 ⁶ CFU/mL
<i>Kocuria rhizophila</i>	1×10 ⁶ CFU/mL	<i>Candida kefyr</i>	1×10 ⁶ CFU/mL
<i>Lactobacillus acidophilus</i>	1×10 ⁶ CFU/mL	<i>Candida lusitanae</i>	1×10 ⁶ CFU/mL
<i>Lactobacillus crispatus</i>	1×10 ⁶ CFU/mL	<i>Candida norvegica</i>	1×10 ⁶ CFU/mL



Organism	Concentration	Organism	Concentration
<i>Lactobacillus gasseri</i>	1×10 ⁶ CFU/mL	<i>Candida rugosa</i>	1×10 ⁶ CFU/mL
<i>Lactobacillus helveticus</i>	1×10 ⁶ CFU/mL	<i>Candida utilis</i>	1×10 ⁶ CFU/mL
<i>Lactobacillus iners</i>	1×10 ⁶ CFU/mL	<i>Kodamaea ohmeri</i> ^a	1×10 ⁶ CFU/mL
<i>Lactobacillus jensenii</i>	1×10 ⁶ CFU/mL	<i>Pichia fermentans</i>	1×10 ⁶ CFU/mL
<i>Lactobacillus johnsonii</i>	1×10 ⁶ CFU/mL	<i>Pichia norvegensis</i> ^b	1×10 ⁶ CFU/mL
<i>Lactobacillus vaginalis</i>	1×10 ⁶ CFU/mL	<i>Pichia occidentalis</i> ^c	1×10 ⁶ CFU/mL
<i>Legionella pneumophila</i>	1×10 ⁶ CFU/mL	<i>Saccharomyces cerevisiae</i>	1×10 ⁶ CFU/mL
<i>Mageeibacillus indolicus</i> ^d	1×10 ⁶ CFU/mL	Viruses	
<i>Megasphaera-2</i>	1×10 ⁶ copies/mL	Hepatitis B virus	1×10 ⁵ IU/mL
<i>Megasphaera elsdenii</i>	1×10 ⁶ CFU/mL	Hepatitis C virus	1×10 ⁵ IU/mL
<i>Mobiluncus curtisii</i>	1×10 ⁶ CFU/mL	Herpes simplex virus I	1×10 ⁵ TCID ₅₀ /mL
<i>Mobiluncus mulieris</i>	1×10 ⁶ CFU/mL	HIV-1	3×10 ⁴ IU/mL ^e
<i>Moraxella catarrhalis</i>	1×10 ⁶ CFU/mL	Human herpesvirus 2	1×10 ⁵ TCID ₅₀ /mL
<i>Morganella morganii</i>	1×10 ⁶ CFU/mL	Human papilloma virus	4.3×10 ⁵ cells/mL
<i>Mycobacterium smegmatis</i>	1×10 ⁶ CFU/mL	Varicella-zoster virus	1×10 ⁵ copies/mL

- a. *Kodamaea ohmeri* is also reported as *Pichia ohmeri* and *Candida guilliermondii*.
- b. *Pichia norvegensis* is also reported as *Candida norvegensis*.
- c. *Pichia occidentalis* is also reported as *Issatchenkia occidentalis* and *Candida sorbose*.
- d. *Mageeibacillus indolicus* is formerly named BVAB3.
- e. Evaluated at highest concentration available

Table 27. Organisms Tested that Showed Cross-Reactivity

Organism	Concentration	Replicates correctly reported results/ Total replicates
<i>Candida orthopsilosis</i>	1×10 ⁶ CFU/mL	0/3
	1×10 ³ CFU/mL	0/3
	1×10² CFU/mL	3/3
<i>Pentatrichomonas hominis</i>	1×10 ⁵ cells/mL	0/3
	5×10⁴ cells/mL	3/3
<i>Trichomonas tenax</i>	1×10 ⁵ cells/mL	0/3
	1×10 ² cells/mL	2/3
	10 cells/mL	3/3

Microbial Interference

An interfering microorganism study was performed to assess the inhibitory effects of microorganisms that may be encountered in vaginal specimens on the performance of Xpert Xpress MVP. Thirteen microorganisms were tested for potential interference at ≥10⁶ CFU/mL for bacteria and at ≥10⁴ International Unit/mL or cells/mL for viruses (Table 28). Each of the microorganisms was tested in simulated vaginal swab matrix in the presence and absence of *Atopobium vaginae* at 3× near cut-off concentrations, *Megasphaera-1* and BVAB2



targets each at $\sim 1.5\times$ near cut-off concentrations, and *Candida albicans*, *C. glabrata* and *Trichomonas vaginalis* targets each at $3\times$ LoD. The results showed that the presence of the tested microorganisms did not interfere with the performance of the Xpert Xpress MVP test.

Table 28. Potentially Interfering Microorganisms Tested

Microorganism
<i>Dialister microaerophilus</i>
<i>Gardnerella vaginalis</i>
<i>Lactobacillus crispatus</i>
<i>Lactobacillus jensenii</i>
<i>Lactobacillus iners</i>
<i>Mageeibacillus indolicus</i>
<i>Mobiluncus curtisii</i>
<i>Porphyromonas asaccharolytica</i>
<i>Prevotella bivia</i>
<i>Sneathia amnii</i>
<i>Streptococcus agalactiae</i>
HIV-1 ^a
Human papilloma virus ^b

a. Evaluated at highest concentration available (3×10^4 IU/mL)

b. Evaluated at 1×10^4 cells/mL

Competitive Interference

Competitive interference between targets (BV, Candida group, *Candida glabrata* and TV) of the Xpert Xpress MVP test caused by co-infections was evaluated by testing each target at low positive concentration in the presence of another target at high concentration in simulated vaginal swab matrix. Competitive inhibitory effects between the BV analytes (Atop gp and Mega1-BVAB2) were also evaluated in simulated vaginal swab matrix. The conditions simulating co-infections were presented in Table 29. Under the conditions of this study, competitive inhibitory effects were not observed between MVP targets or BV analytes with the Xpert Xpress MVP test.

Table 29. Competitive Interference Testing Conditions

	Testing Panel	Testing Target/Organisms (Low Positive)	Competitive Target/Organisms (High Positive)
Competitive Interference Evaluation between MVP Targets	1	<i>Atopobium vaginae</i> ($< 3\times$ near cut-off concentration)	<i>Candida albicans</i> (1×10^6 CFU/mL)
	2	and BVAB2 ($< 3\times$ near cut-off concentration)	<i>Candida glabrata</i> (1×10^6 CFU/mL)



	Testing Panel	Testing Target/Organisms (Low Positive)	Competitive Target/ Organisms (High Positive)
	3		<i>Trichomonas vaginalis</i> (1×10 ⁵ cells/mL)
	4	<i>Atopobium vaginae</i> ($< 3\times$ near cut-off concentration) and <i>Megasphaera-1</i> ($< 3\times$ near cut-off concentration)	<i>Candida albicans</i> (1×10 ⁶ CFU/mL)
	5		<i>Candida glabrata</i> (1×10 ⁶ CFU/mL)
	6		<i>Trichomonas vaginalis</i> (1×10 ⁵ cells/mL)
	7	<i>Atopobium vaginae</i> ($< 3\times$ near cut-off concentration), BVAB2 ($< 1.5\times$ near cut-off concentration) and <i>Megasphaera-1</i> ($< 1.5\times$ near cut-off concentration)	<i>Candida albicans</i> (1×10 ⁶ CFU/mL)
	8		<i>Candida glabrata</i> (1×10 ⁶ CFU/mL)
	9		<i>Trichomonas vaginalis</i> (1×10 ⁵ cells/mL)
	10	<i>Atopobium vaginae</i> ($< 3\times$ near cut-off concentration) in the absence of BVAB2 and <i>Megasphaera-1</i>	<i>Candida albicans</i> (1×10 ⁶ CFU/mL)
	11		<i>Candida glabrata</i> (1×10 ⁶ CFU/mL)
	12		<i>Trichomonas vaginalis</i> (1×10 ⁵ cells/mL)
	13	<i>Candida albicans</i> ($< 3\times$ LoD)	<i>Atopobium vaginae</i> (1×10 ⁷ CFU/mL), BVAB2 (1×10 ⁷ copies/mL) and <i>Megasphaera-1</i> (1×10 ⁷ copies/mL)
	14		<i>Atopobium vaginae</i> (1×10 ⁷ CFU/mL) in the absence of BVAB2 and <i>Megasphaera-1</i>
	15		<i>Candida glabrata</i> (1×10 ⁶ CFU/mL)
	16		<i>Trichomonas vaginalis</i> (1×10 ⁵ cells/mL)



	Testing Panel	Testing Target/Organisms (Low Positive)	Competitive Target/Organisms (High Positive)	
	17	<i>Candida glabrata</i> ($< 3 \times \text{LoD}$)	<i>Atopobium vaginae</i> (1×10^7 CFU/mL), BVAB2 (1×10^7 copies/mL) and <i>Megasphaera-1</i> (1×10^7 copies/mL)	
	18		<i>Atopobium vaginae</i> (1×10^7 CFU/mL) in the absence of BVAB2 and <i>Megasphaera-1</i>	
	19		<i>Candida albicans</i> (1×10^6 CFU/mL)	
	20		<i>Trichomonas vaginalis</i> (1×10^5 cells/mL)	
	21	<i>Trichomonas vaginalis</i> ($< 3 \times \text{LoD}$)	<i>Atopobium vaginae</i> (1×10^7 CFU/mL), BVAB2 (1×10^7 copies/mL) and <i>Megasphaera-1</i> (1×10^7 copies/mL)	
	22		<i>Atopobium vaginae</i> (1×10^7 CFU/mL) in the absence of BVAB2 and <i>Megasphaera-1</i>	
	23		<i>Candida albicans</i> (1×10^6 CFU/mL)	
	24		<i>Candida glabrata</i> (1×10^6 CFU/mL)	
	Competitive Interference Evaluation between BV Organisms	25	<i>Atopobium vaginae</i> ($< 3 \times$ near cut-off concentration)	BVAB2 (1×10^7 copies/mL) and <i>Megasphaera-1</i> (1×10^7 copies/mL)
		26	BVAB2 ($< 3 \times$ near cut-off concentration)	<i>Atopobium vaginae</i> (1×10^6 CFU/mL)



	Testing Panel	Testing Target/Organisms (Low Positive)	Competitive Target/ Organisms (High Positive)
	27	<i>Megasphaera</i> -1 ($< 3\times$ near cut-off concentration)	<i>Atopobium vaginae</i> (1×10^6 CFU/mL)
	28	BVAB2 ($< 1.5\times$ near cut-off concentration) and <i>Megasphaera</i> -1 ($< 1.5\times$ near cut-off concentration)	<i>Atopobium vaginae</i> (1×10^6 CFU/mL)

Potentially Interfering Substances

Twenty substances that may be present in the vaginal swab specimens with the potential to interfere with the performance of Xpert Xpress MVP were evaluated. The potentially interfering substances included prescription and over-the-counter drugs, creams and/or gels, blood, hormones, semen and mucus. The substances, active ingredients, and concentrations tested are listed in [Table 30](#). Potential interferents were tested in simulated vaginal swab matrix in the presence and absence of Xpert Xpress MVP targets at $3\times$ LoD/ $3\times$ near cut-off concentrations. With the exception of the 5.5% concentration of mucin (from porcine stomach), no clinically significant inhibitory effects from substances that may be encountered in vaginal specimens were observed on the performance of the Xpert Xpress MVP test. When mucin was tested at a concentration of 4.0%, no clinically significant inhibitory effect was observed on the performance of the Xpert Xpress MVP test. This is addressed in [Limitations](#).

Table 30. Potential Interfering Substances Tested

Substance/Class	Active Ingredient	Concentration Tested
Blood	Blood	5.0% v/v
Seminal Fluid	Semen	5.0% v/v
Mucus	Mucin (porcine stomach)	5.5% v/v (Interference Observed)
		4.0% v/v (Interference not Observed)
Leukocytes	Leukocytes	10^5 cells/mL
Intravaginal Hormones	Estradiol; Progesterone	7mg/mL Progesterone + 0.07mg/mL Beta Estradiol
Over the counter (OTC) Vaginal Products; Contraceptives; Vaginal treatments	Benzocaine 5%; Resorcinol 2%	0.25% w/v
	Clotrimazole 2%	0.25% w/v
	Miconazole Nitrate 4%	0.25% w/v
	Tioconazole 6.5%	0.25% w/v
	5% w/w acyclovir	0.25% w/v
	Glycerin, Propylene glycol	0.25% w/v
	Glycerin; carbomer	0.25% w/v



Substance/Class	Active Ingredient	Concentration Tested
	Glycerin; sodium hydroxide; carbomer	0.25% w/v
	Glycerin, Hydroxyethyl cellulose	0.25% w/v
	Berberis Vulgaris 6X HPUS (Barberry), Borax 3X HPUS (Sodium Borate), Collinsonia Canadensis 3X HPUS (Stone Root), Hamamelis Virginiana 6X HPUS (Witch Hazel), <i>Bacillus coagulans</i> (Lactospore [®])	0.25% w/v
	Povidone-iodine 10% (topical)	0.25% v/v
	Povidone-iodine 0.3% (douche)	0.25% v/v
	Nonoxynol-9 12.5%	0.25% w/v
	Metronidazole 0.75%	0.25% w/v
Hemorrhoidal Cream	Glycerin 14%; Pramoxine HCL 1%	0.25% w/v

Carry-over Contamination

A study was conducted to demonstrate that single-use, self-contained GeneXpert cartridges prevent specimen and amplicon carry-over contamination from very high titer positive samples into successively run negative samples when processed in the same GeneXpert module. The study consisted of a negative sample processed in the same GeneXpert module immediately after processing a very high BV positive sample (an *A. vaginae* strain at 2.8×10^7 CFU/mL and BVAB2 plasmid DNA at 5.0×10^8 copies/mL), a very high Candida group sample (a *C. albicans* strain at 3.0×10^6 CFU/mL), or a very high TV sample (a *T. vaginalis* strain at 5.0×10^6 cells/mL) in simulated vaginal swab matrix. The testing scheme was repeated 20 times in a single GeneXpert module for a total of 41 runs (20 high positive samples and 21 negative samples per module) across 3 GeneXpert modules. There was no evidence of any carry-over contamination. All 63 negative samples were correctly reported as negative/not detected. All 60 positive samples were correctly reported as positive/detected.

Reproducibility

Reproducibility and precision of the Xpert Xpress MVP test was established through a multicenter (3 sites), blinded study utilizing a multi-factor nested design consisting of contrived panel members spanning the relevant limit of detection (LoD) spectrum (or, in the case of BV, the near cut-off concentration) for the 4 intended target types.

A panel of ten panel members with varying concentrations of the intended target types were tested by two operators in duplicate on six different days at three sites using three lots of Xpert Xpress MVP test cartridges. The total number of tests for each panel member was 144 (3 sites \times 3 lots \times 2 days \times 2 operators \times 2 runs \times 2 replicates). The three concentrations for each intended target type included two positive levels (moderate positives at $\sim 3 \times$ LoD/near cut-off concentration, low positives at $\sim 1 \times$ LoD/near cut-off concentration) and one negative. For the BV target, a high negative level ($< 1 \times$ near the cut-off concentration) was also included.

Percent agreement for each panel member was analyzed across each of the 6 operators and across each of the 3 sites. Overall percent agreement for each panel member was calculated, as well as the Wilson Score 95% confidence interval for each proportion of concordance (Table 31).



Table 31. Summary of Reproducibility and Precision Results

Panel member	Site 01			Site 02			Site 03			Overall Agreement and 95% CI
	Op 1	Op 2	Subtotal	Op 1	Op 2	Subtotal	Op 1	Op 2	Subtotal	
Negative	100% (24/24)	100% (24/24)	100% (48/48)	100% (24/24)	100% (24/24)	100% (48/48)	100% (24/24)	100% (24/24)	100% (48/48)	100% (144/144) 97.4% - 100%
BV, High Neg	66.7% (16/24)	83.3% (20/24)	75.0% (36/48)	41.7% (10/24)	62.5% (15/24)	52.1% (25/48)	54.2% (13/24)	45.8% (11/24)	50.0% (24/48)	59.0% (85/144) 50.9% - 66.7%
BV, Low Pos	91.7% (22/24)	100% (24/24)	95.8% (46/48)	95.8% (23/24)	95.8% (23/24)	95.8% (46/48)	100% (24/24)	100% (24/24)	100% (48/48)	97.2% (140/144) 93.1% - 98.9%
BV, Mod Pos	100% (24/24)	100% (24/24)	100% (48/48)	100% (24/24)	100% (24/24)	100% (48/48)	100% (24/24)	100% (24/24)	100% (48/48)	100% (144/144) 97.4% - 100%
<i>C. albicans</i> , Low Pos	95.8% (23/24)	100% (24/24)	97.9% (47/48)	100% (24/24)	100% (24/24)	100% (48/48)	100% (24/24)	100% (24/24)	100% (48/48)	99.3% (143/144) 96.2% - 99.9%
<i>C. albicans</i> , Mod Pos	100% (24/24)	100% (24/24)	100% (48/48)	100% (24/24)	100% (24/24)	100% (48/48)	100% (24/24)	100% (24/24)	100% (48/48)	100% (144/144) 97.4% - 100%
<i>C. glabrata</i> , Low Pos	100% (24/24)	100% (24/24)	100% (48/48)	95.8% (23/24)	100% (24/24)	97.9% (47/48)	100% (24/24)	100% (24/24)	100% (48/48)	99.3% (143/144) 96.2% - 99.9%
<i>C. glabrata</i> , Mod Pos	100% (24/24)	100% (24/24)	100% (48/48)	100% (24/24)	100% (24/24)	100% (48/48)	100% (24/24)	100% (24/24)	100% (48/48)	100% (144/144) 97.4% - 100%
TV, Low Pos	95.8% (23/24)	95.8% (23/24)	95.8% (46/48)	91.7% (22/24)	95.8% (23/24)	93.8% (45/48)	87.5% (21/24)	100% (24/24)	93.8% (45/48)	94.4% (136/144) 89.4% - 97.2%
TV, Mod Pos	100% (24/24)	100% (24/24)	100% (48/48)	100% (24/24)	100% (24/24)	100% (48/48)	100% (24/24)	100% (24/24)	100% (48/48)	100% (144/144) 97.4% - 100%

Abbreviations: Mod, moderate; Neg, negative; Op, operator; Pos, positive

The reproducibility of the Xpert Xpress MVP test was also evaluated in terms of the fluorescence signal expressed in Ct values for each target detected. The mean, standard deviation (SD), and coefficient of variation (CV) between-sites, between-lots, between-days, between-operators, between-runs and within-run for each panel member are presented in [Table 32](#).



Table 32. Results of Reproducibility for the Xpert Xpress MVP Test

Panel Member	Analyte	N ^a	Mean Ct	Site		Lot		Day		Operator		Between-Run		Within-run		Total	
				SD	CV (%)	SD	CV (%)	SD	CV (%)	SD	CV (%)	SD	CV (%)	SD	CV (%)	SD	CV (%)
Negative	SPC	144	32.66	0.06	0.2	0.17	0.5	0	0	0.24	0.7	0	0	0.37	1.1	0.48	1.5
BV, High Neg	Atop gp	144	32.45	0.07	0.2	0.17	0.5	0	0	0.12	0.4	0.05	0.2	0.28	0.9	0.36	1.1
BV, Low Pos		144	31.95	0.03	0.1	0.19	0.6	0	0	0	0	0.27	0.8	0.51	1.6	0.61	1.9
BV, Mod Pos		144	30.56	0	0	0.20	0.7	0.13	0.4	0.10	0.3	0.14	0.4	0.30	1.1	0.42	1.4
BV, High Neg	Mega1-BVAB2	111	41.08	0.26	0.6	0.27	0.7	0	0	0.35	0.9	0	0	1.28	3.1	1.38	3.4
BV, Low Pos		144	36.31	0	0	0.31	0.9	0	0	0	0	0.23	0.6	0.58	1.6	0.70	1.9
BV, Mod Pos		144	35.25	0.16	0.5	0.19	0.5	0.19	0.5	0	0	0	0	0.59	1.7	0.67	1.9
<i>C. albicans</i> , Low Pos	Cgroup	144	36.67	0	0	0.22	0.6	0	0	0.19	0.5	0.56	1.5	0.78	2.1	1.01	2.7
<i>C. albicans</i> , Mod Pos		144	35.00	0.27	0.8	0	0	0	0	0.60	1.7	0.45	1.3	0.55	1.6	0.96	2.8
<i>C. glabrata</i> , Low Pos	Cglab-krus	143	31.79	0	0	0.35	1.1	0	0	0	0	0.37	1.2	1.35	4.2	1.44	4.5
<i>C. glabrata</i> , Mod Pos		144	29.75	0.54	1.8	0.22	0.8	0.34	1.1	0.47	1.6	0.07	0.2	0.90	3.0	1.22	4.1
TV, Low Pos	TV	136	38.41	0.21	0.6	0.22	0.6	0	0	0.33	0.9	0	0	1.23	3.2	1.30	3.4
TV, Mod Pos		144	35.97	0.15	0.4	0.09	0.3	0	0	0.07	0.2	0.23	0.6	0.50	1.4	0.58	1.6

a. Number of samples with Ct values out of 144.

Abbreviations: Atop gp, Atopobium group; Cglab-krus, *C. glabrata*/*C. krusei*; Cgroup, *Candida* spp.; CV, coefficient of variance; Mega1; *Megasphaera*-1; Mod, moderate; Neg, negative; Pos, positive; SD, standard deviation; SPC; sample processing control

Note The variance estimate from some factors may be numerically negative, which can occur if the variability due to those factors is very small. When this occurs, the variability as measured with SD and CV is set to 0.

Precision of the BV Target

Due to the diversity of organisms associated with the detection of BV, a separate single-site study was conducted to establish precision of the BV target. To establish the test precision for the BV targets in the Xpert Xpress MVP test, a single-center, blinded precision study was conducted utilizing samples with unique combinations of contrived BV organisms.

A panel of nine panel members were tested by two operators in duplicate on ten different days using one lot



of Xpert Xpress MVP test cartridges. The total number of tests for each panel member was 80 (1 site × 1 lot × 10 days × 2 operators × 2 runs × 2 replicates). The panel included 1 negative panel member, a high negative level (<1× the near cut-off concentration), and two positive levels (low positives at ~1× the near cut-off concentration, and moderate positives at ~3× the near cut-off concentration) utilizing unique combinations of the BV organisms (*Atopobium vaginae*, *Megasphaera-1*, and BVAB2).

As shown in Table 33, agreement for each panel member was calculated, as well as the Wilson Score 95% confidence interval for each proportion of concordance.

Table 33. Summary of Precision Results for the BV Target

Sample Type	Overall Agreement	95% CI
Negative	100% (80/80)	95.4% - 100%
<i>A. vaginae</i> , Low positive	97.5% (78/80)	91.3% - 99.3%
<i>A. vaginae</i> and BVAB2, High negative	66.3% (53/80)	55.4% - 75.7%
<i>A. vaginae</i> and BVAB2, Low positive	97.5% (78/80)	91.3% - 99.3%
<i>A. vaginae</i> and <i>Megasphaera-1</i> , High negative	23.8% (19/80)	15.8% - 34.1%
<i>A. vaginae</i> and <i>Megasphaera-1</i> , Low positive	95.0% (76/80)	87.8% - 98.0%
<i>A. vaginae</i> , BVAB2, and <i>Megasphaera-1</i> , High negative	53.8% (43/80)	42.9% - 64.3%
<i>A. vaginae</i> , BVAB2, and <i>Megasphaera-1</i> , Low positive	96.3% (77/80)	89.5% - 98.7%
<i>A. vaginae</i> , BVAB2, and <i>Megasphaera-1</i> , Moderate positive	100% (80/80)	95.4% - 100%

Abbreviations: *A. vaginae*; *Atopobium vaginae*

Precision for BV targets was evaluated in terms of the fluorescence signal expressed in Ct values for each target detected. The mean, standard deviation (SD), and coefficient of variation (CV) between-days, between-operators, between-runs and within-run for each panel member are presented in Table 34.

Table 34. Results of Precision for the BV Target

Panel member	Analyte	N ^a	Mean Ct	Day		Operator		Between-Run		Within-run		Total	
				SD	CV (%)	SD	CV (%)	SD	CV (%)	SD	CV (%)	SD	CV (%)
Negative	SPC	80	32.84	0.00	0.0	0.49	1.5	0.22	0.7	0.90	2.7	1.05	3.2
<i>A. vaginae</i> , Low Pos	Atop gp	80	24.98	0.00	0.0	0.00	0.0	0.03	0.1	0.32	1.3	0.32	1.3
<i>A. vaginae</i> and BVAB2, High Neg	SPC	80	32.64	0.17	0.5	0.17	0.5	0.12	0.4	0.37	1.1	0.46	1.4
	Atop gp	80	32.35	0.00	0.0	0.16	0.5	0.00	0.0	0.20	0.6	0.26	0.8
	Mega1-BVAB2 ^b	75	41.30	0.37	0.9	0.00	0.0	0.26	0.6	1.15	2.8	1.24	3.0
<i>A. vaginae</i> and BVAB2, Low Pos	Atop gp	80	32.20	0.00	0.0	0.04	0.1	0.08	0.3	0.22	0.7	0.24	0.7
	Mega1-BVAB2 ^b	80	40.03	0.00	0.0	0.00	0.0	0.30	0.7	0.90	2.2	0.94	2.4
<i>A. vaginae</i> and Mega-1, High Neg	SPC	80	32.63	0.11	0.3	0.17	0.5	0.00	0.0	0.39	1.2	0.44	1.3
	Atop gp	80	32.62	0.00	0.0	0.04	0.1	0.00	0.0	0.33	1.0	0.34	1.0
	Mega1-BVAB2 ^b	28	38.98	0.00	0.0	1.01	2.6	0.21	0.6	0.84	2.2	1.33	3.4
<i>A. vaginae</i> and Mega-1, Low Pos	Atop gp	79	32.07	0.00	0.0	0.15	0.5	0.18	0.6	0.41	1.3	0.47	1.5
	Mega1-BVAB2 ^b	80	35.48	0.00	0.0	0.29	0.8	0.00	0.0	0.71	2.0	0.77	2.2



Panel member	Analyte	N ^a	Mean Ct	Day		Operator		Between-Run		Within-run		Total	
				SD	CV (%)	SD	CV (%)	SD	CV (%)	SD	CV (%)	SD	CV (%)
<i>A. vaginae</i> , BVAB2, and Mega-1, High Neg	SPC	80	32.74	0.15	0.5	0.12	0.4	0.17	0.5	0.33	1.0	0.41	1.3
	Atop gp	80	32.53	0.00	0.0	0.15	0.5	0.00	0.0	0.22	0.7	0.27	0.8
	Mega1-BVAB2 ^b	63	41.57	0.30	0.7	0.00	0.0	0.39	0.9	1.02	2.5	1.13	2.7
<i>A. vaginae</i> , BVAB2, and Mega-1, Low Pos	Atop gp	79	31.81	0.00	0.0	0.22	0.7	0.28	0.9	1.16	3.6	1.21	3.8
	Mega1-BVAB2 ^b	80	36.25	0.15	0.4	0.00	0.0	0.10	0.3	0.69	1.9	0.71	2.0
<i>A. vaginae</i> , BVAB2, and Mega-1, Mod Pos	Atop gp	80	30.67	0.13	0.4	0.09	0.3	0.00	0.0	0.33	1.1	0.37	1.2
	Mega1-BVAB2 ^b	80	35.64	0.00	0.0	0.26	0.7	0.00	0.0	0.48	1.3	0.54	1.5

a. Number of samples with non-zero Ct values out of 80.

b. Samples with Mega1-BVAB2 that did not generate a Ct value were excluded from analysis.

Abbreviations: Atop gp, Atopobium group; CV, coefficient of variance; Mega1, *Megasphaera-1*; Mod; moderate; Neg, negative; Pos, positive; SD, standard deviation; SPC, sample processing control

Note The variance estimate from some factors may be numerically negative, which can occur if the variability due to those factors is very small. When this occurs, the variability as measured with SD and CV is set to 0.

The BV-associated organisms targeted by the Xpert Xpress MVP test demonstrated acceptable precision.

? Appendix

Bibliography

1. Hainer BL, Gibson MV. Vaginitis. *Am Fam Physician*. 2011;83(7): 807-815.
2. Centers for Disease Control and Prevention. *Biosafety in Microbiological and Biomedical laboratories* (refer to latest edition). <http://www.cdc.gov/biosafety/publications/>
3. Clinical and Laboratory Standards Institute. *Protection of Laboratory Workers from Occupationally Acquired Infections; Approved Guideline*. Document M29 (refer to latest edition).
4. Chemical hazards determined under REGULATION (EC) No 1272/2008 OF THE EUROPEAN PARLIAMENT AND OF THE COUNCIL of 16 December 2008 (on classification, labeling and packaging of substances and mixtures amending and repealing Directives 67/548/EEC and 1999/45/EC, and amending Regulation (EC) No 1907/2006) and the Occupational Safety and Health Standards, Hazard Communication, Toxic and Hazard Substances (March 26, 2012) (29 C.F.R., pt. 1910, subpt. Z), can be referenced on the Safety Data Sheet available at www.cepheid.com and www.cepheidinternational.com under the **SUPPORT** tab.

Cepheid Headquarters Locations

Corporate Headquarters

Cepheid
904 Caribbean Drive
Sunnyvale, CA 94089
USA

Telephone: + 1 408 541 4191
Fax: + 1 408 541 4192
www.cepheid.com

European Headquarters

Cepheid Europe SAS
Vira Solelh
81470 Maurens-Scopont
France

Telephone: + 33 563 825 300



Fax: + 33 563 825 301
www.cepheidinternational.com

Technical Assistance

Before Contacting Us

Collect the following information before contacting Cepheid Technical Support:

- Product name
- Lot number
- Serial number of the instrument
- Error messages (if any)
- Software version and, if applicable, Computer Service Tag Number

United States Technical Support









Telephone: + 1 888 838 3222
Email: techsupport@cepheid.com

France Technical Support



Telephone: + 33 563 825 319
Email: support@cepheideurope.com

Contact information for all Cepheid Technical Support offices is available on our website: www.cepheid.com/en/support/contact-us.

Table of Symbols

Symbol	Meaning
	Catalog number
	<i>In vitro</i> diagnostic medical device
	Do not reuse
	Batch code
	Consult instructions for use
	Manufacturer
	Country of manufacture
	Contains sufficient for n tests
	Expiration date



Symbol	Meaning
	Temperature limitation
	For prescription use only



Cepheid
904 Caribbean Drive
Sunnyvale, CA 94089
USA



Revision History

Description of Changes: 303-0949 Rev. A

Purpose: Initial release

